

THE COLD SOURCE TECHNIQUE FOR NOISE FIGURE MEASUREMENTS

Products:

- ▶ R&S®ZNA26
- ▶ R&S®ZNA43
- ▶ R&S®ZNA50
- ▶ R&S®ZNA67

Mike Leffel, Christopher Stumpf | 1SL378 | Version 0e | 12.2021

<http://www.rohde-schwarz.com/appnote/1SL378>

ROHDE & SCHWARZ

Make ideas real



Contents

1	Overview.....	4
2	Introduction.....	5
2.1	What is Noise Figure	5
3	Background Theory and Equations.....	6
3.1	Basic Equations	6
3.2	Thermal Noise of Resistors	7
3.3	Deriving Noise Figure Equations.....	9
3.3.1	Friis Derivation	9
3.3.2	IEEE Definition of Noise Figure.....	10
3.3.3	Consistency between Friis and the IEEE Definition for NF.....	10
3.4	Equivalent Noise Temperature	11
3.5	When to Use Noise Figure vs Noise Temperature	12
3.6	Friis Cascade Equations	12
3.7	Examples	13
3.7.1	Calculate Noise Figure and Temperature from Output Noise Power	13
3.7.2	Calculate Noise Figure of a Cascade.....	14
4	The R&S®ZNA Noise Figure Application.....	15
4.1	Required Equipment and Options	15
4.2	Setup a Noise Figure Channel	16
4.2.1	Configure the Noise Figure Channel	16
4.2.2	Enter Measurement and DUT Settings.....	18
4.2.3	Select the Hardware Configuration	19
4.2.4	Select the Desired Trace Noise.....	19
4.2.5	Compare Quickset Proposal with the Physical Setup	20
4.3	Calibrate the Noise Figure Channel	20
4.3.1	S-Parameter Calibration.....	21
4.3.2	Power Calibration.....	22
4.3.3	Receiver Noise Calibration.....	23
4.4	Measure the DUT	24
4.5	Measurement Improvements.....	26
4.5.1	Detector Times.....	26
4.5.2	Averaging	26
4.5.3	Advanced Settings	27
4.5.4	Check for Compression.....	30
5	Hardware Options for NF Measurements.....	32
5.1	Port 1 Hardware Options.....	32
5.1.1	B21 Source Step Attenuator.....	33
5.1.2	B161 Source Monitor Connection	33
5.1.3	B31 Measurement Receiver Step Attenuator	34

5.1.4	B501 Measurement Receiver Isolation Amplifier.....	35
5.2	Port 2 Hardware Options.....	35
5.2.1	B32 Measurement Receiver Step Attenuator	36
5.2.2	B302 Low Noise Pre-Amplifier	37
5.2.3	Reversed Coupler	37
5.2.4	External Low Noise Amplifiers.....	38
6	Conclusion	39
7	Literature	40
8	Ordering Information	41

1 Overview

Noise figure is an important parameter that describes the noise contribution of an electronic device. A classical approach to measure the noise figure is to use a noise source which delivers two different input noise powers by switching between a “hot” and a “cold” state and a noise receiver (e.g. a spectrum analyzer).

In contrast to this approach, using a vector network analyzer with the “Cold Source” approach eliminates the need for a noise source. A cold source noise power measurement followed by an available gain measurement of the device under test is sufficient to determine the noise figure of the device. This application note describes the “Cold Source” technique for measuring noise figure on the R&S®ZNA family of vector network analyzers.

Background equations are provided for an analysis of noise factor, noise figure and noise temperature on a device under test and a cascade of devices.

Based on a measurement example the user will be guided through the process of setting up a noise figure channel and performing a noise figure measurement. In addition, various measurement options are reviewed, providing guidance as to when and how each option should be utilized to improve the noise figure results.

2 Introduction

There are two primary techniques utilized to measure noise figure:

The first is the Y-factor technique typically used on spectrum analyzers, which utilizes a noise source connected to the input of the device under test (DUT), and measures the output noise of the DUT under two conditions: With the noise source turned on and with the noise source turned off. These two measurements are used to calculate the noise figure and the gain of the DUT.

The second is the cold source technique, which terminates the input of the DUT with a resistance equal to the system impedance, and measures the output noise power of the DUT. In a second step the gain of the DUT is measured, and the two results are utilized to calculate the noise figure. Due to the separate gain measurement, the cold source technique is typically used with vector network analyzers (VNAs).

The Y-factor technique is described in detail in the Rohde & Schwarz Application note, “The Y Factor Technique for Noise Figure Measurements,” which is available on the Rohde and Schwarz website under application note number 1MA-178, and found at the following URL:

https://www.rohde-schwarz.com/us/applications/the-y-factor-technique-for-noise-figure-measurements-application-note_56280-15484.html

This application note, “The Cold Source Technique for Noise Figure Measurements,” describes the cold source technique as it is implemented on the R&S®ZNA vector network analyzer.

2.1 What is Noise Figure

The noise figure of a device provides a quantifiable measure of the noise that the device under test (DUT) adds to a signal as that signal passes through the DUT. It is a common figure of merit found on specification sheets for many types of RF and microwave components, assemblies and devices.

Noise figure is most often associated with active devices such as amplifiers and receivers. An ideal amplifier will boost a signal to a higher level without adding any noise to the signal. A real amplifier, due to various sources of noise, such as thermal noise, shot noise, flicker noise, etc., will always add some noise to the signal, degrading the signal quality in some way. Noise figure is a metric that quantifies how much noise is added to the signal by the DUT.

Noise figure is defined by the IEEE [1] in a way that allows devices to be compared to each other. It joins the list of other basic RF metrics such as 3rd order intercept point, compression point, dynamic range, and so on; allowing engineers to evaluate the fit of a particular device to an application or need.

This application note uses the IEEE definition for noise figure. See section 3.3.2 for details.

3 Background Theory and Equations

To make a noise figure measurement using the cold source technique there is a need to convert between different quantities such as noise figure, noise factor, noise temperature, linear gain, logarithmic gain, linear power, logarithmic power and so on. The equations needed for these conversions are listed in this section for reference. These equations can be found in many references, e.g. in [2].

3.1 Basic Equations

As a convention, logarithmic parameters will be denoted with the suffix “dB” or “dBm” in the variable name and also in its units. For an example, see equations (1) and (2).

The next convention in this application note is to use the symbol log for the base 10 logarithmic conversion. All conversions from the linear domain to the logarithmic domain use base 10 logarithms.

Starting with a linear power P in units of Watts, the first conversion is to express the linear power in the logarithmic domain. All logarithmic powers in this application note will be in units of dBm, which is a logarithmic ratio of the linear power to 1 mW:

$$P_{dBm} = 10 \log\left(\frac{P}{0.001 \text{ W}}\right) \text{ dBm.} \quad (1)$$

The inverse relationship converts a log power P_{dBm} to a linear power P in Watts:

$$P = (0.001 \text{ W}) \cdot 10^{(P_{dBm}/10)}. \quad (2)$$

For clarity, in this application note, noise factors will use the symbol F , and the logarithmic term noise figure will use the symbol NF . It then follows that noise factor is converted to logarithmic noise figure using (3):

$$NF = 10 \log(F) \text{ dB.} \quad (3)$$

And the inverse equation is given as

$$F = 10^{(NF/10)}. \quad (4)$$

This next equation converts linear power gain G to logarithmic gain:

$$G_{dB} = 10 \log(G) \text{ dB.} \quad (5)$$

And the inverse equation is given as

$$G = 10^{(G_{dB}/10)}. \quad (6)$$

For lossy elements, linear power loss is related to power gain as follows

$$G = \frac{1}{L}. \quad (7)$$

And in the logarithmic domain

$$G_{dB} = -L_{dB}. \quad (8)$$

For example, a 3 dB attenuator has -3 dB of gain, or $+3$ dB of loss.

Noise factor (linear) is related to noise temperature of a DUT by equation (9). Equation (9) is derived in section 3.4, but included here for reference:

$$T_{DUT} = T_0 \cdot (F - 1). \quad (9)$$

T_0 is the standard reference temperature as defined by the IEEE:

$$T_0 = 290 \text{ K}. \quad (10)$$

The inverse equation follows as

$$F = \frac{T_{DUT}}{T_0} + 1 \quad (11)$$

Noise figure (in the logarithmic domain) can then be related to noise temperature by combining equations (4) and (9):

$$T_{DUT} = T_0 \cdot (10^{(NF/10)} - 1). \quad (12)$$

The inverse equation follows from (3) and (11):

$$NF = 10 \log \left(\frac{T_{DUT}}{T_0} + 1 \right) \text{ dB}. \quad (13)$$

3.2 Thermal Noise of Resistors

All resistors create thermal noise (Johnson noise or Nyquist noise) due to electron movement. A resistor of resistance R_n at a physical temperature T_{phys} will create an RMS voltage at its terminals of

$$v_n = \sqrt{\frac{4hfBR_n}{e^{hf/(kT_{phys})} - 1}} \quad (14)$$

where

$k = 1.38 \cdot 10^{-23} \text{ J/K}$ is Boltzmann's constant,

$h = 6.63 \cdot 10^{-34} \text{ J/Hz}$ is Planck's constant,

B is the bandwidth of the system

and f is the center frequency of the bandwidth in Hz.

The derivation of equation (14) was done by Nyquist in 1928 published in [3].

Using the Rayleigh-Jeans approximation

$$\frac{hf}{kT_{phys}} \ll 1 \Rightarrow e^{\frac{hf}{kT_{phys}}} \approx 1 + \frac{hf}{kT_{phys}} \quad (15)$$

equation (14) simplifies to:

$$v_n \approx \sqrt{4kT_{phys}BR_n}. \quad (16)$$

Using this approximation, a "real" resistor can be modeled as a noise voltage source followed by an ideal or "noiseless" resistor. Since this is a noise signal, the noise (voltage source) will create a random voltage over

time, which statistically follows a Gaussian distribution. It has mean value of 0 volts, and a standard deviation of v_n , as given in equation (16).

If this noise source and ideal resistor are connected to a resistive load with resistance R_L through an ideal band pass filter with a 1 Hz bandwidth (Figure 3-1), then the RMS noise power delivered to the load is bandwidth limited, and is given as:

$$P_n = \frac{(v_L)^2}{R_L}. \quad (17)$$

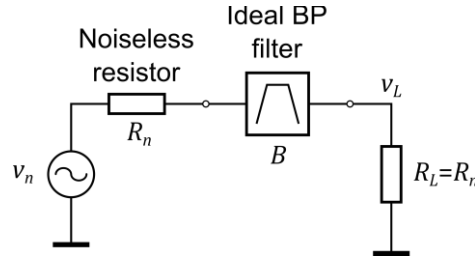

Figure 3-1: Noise dissipated in a matched load due to a noise source

If the load resistance is matched to the noise resistance ($R_L = R_n$), then the available power $P_{n,av}$ of the source will be dissipated in the load. The noise voltage at the load terminals is

$$v_L \approx \frac{1}{2} \left(\sqrt{4kT_{phys}BR_L} \right). \quad (18)$$

Combining equations (17) and (18), the RMS noise power dissipated in the load is

$$P_{n,av} \approx kT_{phys}B. \quad (19)$$

When using the definition of a noise temperature

$$T_n = \frac{P_{n,av}}{kB} \quad (20)$$

the combination of equations (19) and (20) shows that $T_n \approx T_{phys}$. From here, the Rayleigh-Jeans approximation will be regarded as accurate enough and will be written as exact solution.

Note: $P_{n,av}$ is the available power of the noise source. This power will be delivered to the load if it is matched to the source. Under this condition, the actual value of the resistor drops out of the equation. For frequency-temperature combinations where the Rayleigh-Jeans approximation applies, the physical temperature of a resistor is approximately equal to its noise temperature of equation (19). This statement is valid for all passive devices.

For $T_n = T_0 = 290$ K (which is 16.85 °C) and $B = 1$ Hz, equation (19) results in:

$$P_{n,0} = 10 \log \left(\frac{(1.38 \cdot 10^{-23} \text{ J/K})(290 \text{ K})(1 \text{ Hz})}{0.001 \text{ W}} \right) = -173.977 \text{ dBm}. \quad (21)$$

The corresponding noise density N_0 is universally referred to as -174 dBm/Hz at the standard reference temperature $T_0 = 290$ K.

3.3 Deriving Noise Figure Equations

Section 3.3.1 covers the derivation of noise figure attributed to Friis [4]. It starts by calculating noise figure as a degradation of the signal to noise ratio (SNR) at the output of the DUT compared to the input of the DUT.

It was later modified by the IEEE to create the IEEE definition for noise figure. The modification is to create a reference input power of kT_0B in all noise figure calculations, with $T_0 = 290$ K, allowing the comparison of the resulting noise figures of different DUTs. The IEEE definition is covered in section 3.3.2.

3.3.1 Friis Derivation

Consider a device with an input consisting of a signal of power S_{in} plus input noise of power N_{in} (Figure 3-2). The gain of the device amplifies both the input signal and the input noise. But in addition, the device creates internal noise and adds it to the overall noise at the output of the DUT. Therefore, the signal to noise ratio at the output of the DUT (SNR_{out}) is worse than the signal to noise ratio at the input of the DUT (SNR_{in}). This effect which degrades the signal to noise ratio at the output compared to the input can be expressed by the noise figure of the DUT.

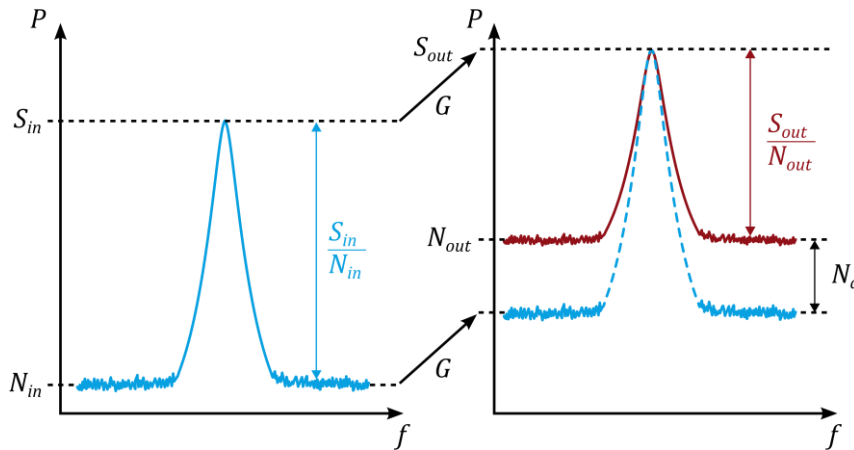

Figure 3-2: Graphical representation of signal to noise ratios at the input and output of a DUT

Friis defined the linear term noise factor as the degradation of the SNR due to the device under test:

$$F_{Friis} = \frac{SNR_{in}}{SNR_{out}} = \frac{S_{in}/N_{in}}{S_{out}/N_{out}} \quad (22)$$

Equation (22) can be manipulated by considering $S_{out} = S_{in} \cdot G$, where G is the available gain of the DUT; and by noting that the input noise to the system is $N_{in} = kT_{in}B$:

$$F_{Friis} = \frac{S_{in}}{kT_{in}B} \frac{N_{out}}{S_{in}G} = \frac{N_{out}}{kT_{in}BG} \quad (23)$$

The output noise N_{out} of the DUT is the input noise N_{in} amplified by the available gain G of the DUT, plus the additive noise N_a created in the DUT itself. In the equivalent block diagram of Figure 3-3, the additive noise of the DUT is referenced to the input of the DUT. The DUT (in this case an amplifier) can then be modelled as noiseless. The additive noise of the DUT could also be referenced to its output. Either technique works, as long as a consistent definition is utilized. In the following derivation, the additive noise is referenced to the input which means that it is amplified by the available gain of the DUT, and hence the additive noise at the output of the DUT is N_aG and the output noise power

$$N_{out} = N_aG + kT_{in}BG = (N_a + kT_{in}B)G. \quad (24)$$

Substituting (24) into (23)

$$F_{Friis} = \frac{N_a}{kT_{in}B} + 1 = \frac{N_a}{N_{in}} + 1 \quad (25)$$

Converting noise factor to the logarithmic domain term noise figure NF is accomplished with equation (3):

$$NF_{Friis} = 10 \log \left(\frac{N_a}{kT_{in}B} + 1 \right). \quad (26)$$

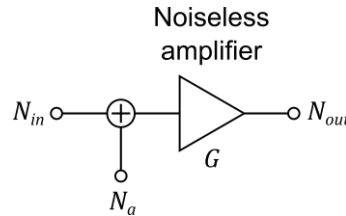

Figure 3-3: Additive noise N_a of an amplifier referenced to its input

This means that noise factor and noise figure are directly related to the additive noise of the DUT. In other words, if the noise figure or noise factor of a DUT is known, then the additive noise N_a of the device can be calculated.

3.3.2 IEEE Definition of Noise Figure

In section 3.3.1, noise figure equations were derived from the Friis signal to noise ratio definition, with the input noise defined as $kT_{in}B$.

The IEEE definition of the noise figure defines the input noise power as $N_{in} = N_0 = kT_0B$. This means that the input noise source is at standard reference temperature T_0 . This standardization allows comparison of different DUTs under common test conditions. The noise figure values that are found in datasheets are usually determined based on the IEEE definition. Using this convention, the noise factor of equation (25) can be written as:

$$F = \frac{N_a}{kT_0B} + 1 = \frac{N_a}{N_0} + 1 \quad (27)$$

3.3.3 Consistency between Friis and the IEEE Definition for NF

The Friis derivation of noise figure is consistent with the IEEE definition for noise figure (see section 2.4) if and only if the input noise power is defined at the standard temperature of $T_0 = 290$ K. This is the assumption made everywhere in this application note:

In this application note, and in nearly all specifications; “noise figure” refers to the IEEE defined noise figure, which also means it is calculated using the standard input noise power of $N_0 = kT_0B$.

One implication of this, is that the IEEE noise figure result is only useful for comparing devices to each other under common test conditions. For example, with the standard input noise power N_0 , which device has a lower noise figure? But once the device has been placed into a system or sub-assembly, and the input noise to the device is determined by the preceding stage, then the actual output noise of the device is not easily related to the IEEE defined noise figure of the device.

Further, if a device has been placed into a system or sub-assembly where the input noise to the device is not $N_{in} = kT_0B$, and then the noise figure of this device is degraded by 1 dB, it does *not* mean the signal to noise ratio of the signal passing through this device will be degraded by 1 dB. The amount of degradation is a function of the noise figure of the device, the signal to noise ratio of the signal at the input of the device, and the noise power at the input of the device.

The previous two paragraphs are a common source of confusion when engineers are first exposed to the concepts of noise figure. The IEEE definition of noise figure uses a “standard” input noise power, which provides a consistent definition and measurement technique for all devices.

But once the device has been placed into a system or sub-assembly, then cascaded calculations **MUST** be performed using actual input noise to each stage in the system. These cascaded calculations will provide details regarding the input and output noise power of every stage in the cascade, along with the input and output signal power at each stage. The analysis of noise figure with cascaded components is covered in section 3.6.

3.4 Equivalent Noise Temperature

Noise temperature is another way of representing noise power. In the case of a resistor at a physical temperature of T_{phys} , the available noise power created by the resistor is approximately $kT_{phys}B$ if the Rayleigh-Jeans approximation is applied. A shorthand method of referring to the equivalent noise power created by this resistor is to create an equivalent noise temperature T_e used in the equation kTB , and set the value of the term equal to the noise power. In this trivial example:

$$kT_e B \approx kT_{phys} B \tag{28}$$

This concept can be applied to the noise added by the DUT (Figure 3-4) to convert from noise power to an equivalent noise temperature referenced to the input of the DUT:

$$N_a = kT_e B \tag{29}$$

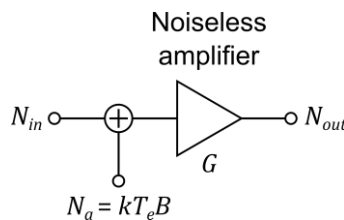

Figure 3-4: Equivalent noise temperature of a DUT referenced to its input

Substituting equation (29) into equation (27), the noise factor equation can be converted to noise temperature:

$$F = \frac{kT_e B}{kT_0 B} + 1 = \frac{T_e}{T_0} + 1 \tag{30}$$

Solving for equivalent noise temperature T_e leads to:

$$T_e = T_0(F - 1) \tag{31}$$

Equations (27) and (30) show that the term noise factor is directly related to the additive noise power N_a of the DUT or to its equivalent noise temperature T_e . So, equivalent noise temperature is another term that describes the amount of additive noise N_a of a DUT.

3.5 When to Use Noise Figure vs Noise Temperature

At first exposure, it can be difficult to decide if the analysis of a device’s noise should be done with noise figure or with noise temperature. Some industries prefer one term over the other, and this will often influence or dictate which terms and equations shall be used. In other situations, the engineer has a choice.

But to be clear, if handled properly, calculations can be performed with noise figure, noise factor or noise temperature, and all will yield the same end result. In fact, equations are provided to convert between noise figure, noise factor and noise temperature. And it is common to convert from one system to the other, in order to use a more convenient or simplified equation for the next step in the calculation.

Care is required to recognize when an equation is calling for the linear term noise factor, vs. the logarithmic term noise figure. A common mistake is to use noise figure in an equation expecting noise factor.

Another common error is to forget that noise figure is defined by the IEEE with a fixed input noise power, defined at the standard reference temperature $T_0 = 290$ K.

It may help to remember that noise figure is a logarithmic scale metric that is related to a ratio of powers. Meanwhile equivalent noise temperature is a linear domain parameter that is directly related to the additive noise power. Noise figure in dB rarely provides a direct calculation of the actual output noise for a DUT. It provides a calculation of the output noise if and only if the input noise is kT_0B . When performing a system analysis or cascaded calculation, then the engineer must use the actual input noise power to the system or sub-assembly if the goal is to calculate the output noise power of the system or sub-assembly.

Because of the way it is defined, equivalent noise temperature T_e represents the portion of the device’s output noise due to the device itself. This means that 1) T_e is not a function of the input power to the device. In addition, 2) noise temperature is in the linear domain. This means that multiple noise temperatures can be directly added together. Finally, 3) noise temperature does not include a term for bandwidth.

These three reasons are why many noise figure calculations convert noise figure (or noise factor) to equivalent noise temperature T_e in a first step, perform all calculations using noise temperatures, and then convert from noise temperature back to noise figure in a final step.

3.6 Friis Cascade Equations

The Friis cascade equation [4] allows the calculation of the noise factor of a cascade of N stages, as long as the noise factor of each stage is known, along with the available gain of the first N-1 stages. The linear equation for noise factor is derived by calculating the input and output signal to noise ratios. In this derivation, the added noise of the stage N_a is referenced to the input of the stage, following the definition used in equations (24), (25) and (26). Figure 3-5 shows a cascade of two amplifiers.

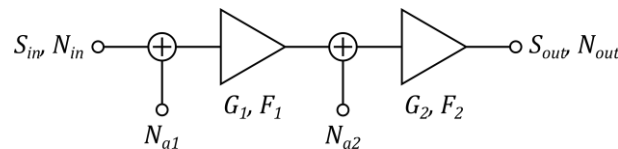

Figure 3-5: Cascade of two amplifiers

The total output noise power N_{out} of two cascaded stages is:

$$N_{out} = N_{in}G_1G_2 + N_{a1}G_1G_2 + N_{a2}G_2 \tag{32}$$

The signal power at the cascade output is:

$$S_{out} = S_{in}G_1G_2 \tag{33}$$

From here the linear noise factor of the cascade can be calculated as

$$F_{total} = \frac{S_{in}/N_{in}}{S_{out}/N_{out}} = \frac{S_{in}N_{out}}{N_{in}S_{in}G_1G_2} \quad (34)$$

Substituting equation (32) into equation (34):

$$F_{total} = \frac{N_{in}G_1G_2 + N_{a1}G_1G_2 + N_{a2}G_2}{N_{in}G_1G_2} = 1 + \frac{N_{a1}}{N_{in}} + \frac{N_{a2}}{N_{in}G_1} \quad (35)$$

If $N_{in} = N_0$ the IEEE definition of the noise factor given in equation (27) can be used to express the total noise factor in terms of the noise factor and the gain of the single stages. The noise factor of the amplifiers is:

$$F_1 = \frac{N_{a1}}{N_0} + 1 \Rightarrow \frac{N_{a1}}{N_0} = \frac{N_{a1}}{N_{in}} = F_1 - 1 \quad (36)$$

and

$$F_2 = \frac{N_{a2}}{N_0} + 1 \Rightarrow \frac{N_{a2}}{N_0} = \frac{N_{a2}}{N_{in}} = F_2 - 1 \quad (37)$$

Substituting equations (36) and (37) into equation (35):

$$F_{total} = F_1 + \frac{F_2 - 1}{G_1} \quad (38)$$

The Friis cascade equation can be extended to N stages, and takes on this form:

$$F_{total} = F_1 + \frac{F_2 - 1}{G_1} + \frac{F_3 - 1}{G_1G_2} + \dots + \frac{F_N - 1}{G_1G_2 \dots G_{N-1}} \quad (39)$$

Note: The IEEE noise factor values in equations (38) and (39) can only be used if $N_{in} = N_0$ at the input of the first stage. If $N_{in} \neq N_0$ equations (36) and (37) will deliver the noise figure defined by Friis but not the noise figure according to the IEEE definition.

The Friis cascade equation can also be written in terms of equivalent noise temperature:

$$T_e = T_1 + \frac{T_2}{G_1} + \frac{T_3}{G_1G_2} + \dots + \frac{T_N}{G_1G_2 \dots G_{N-1}} \quad (40)$$

with the equivalent noise temperatures $T_1 \dots T_N$ of the different stages. In contrast to equation (39), equation (40) is independent of the input noise power. For the conversion from noise temperature T_e to noise factor of the cascade F_{total} equation (30) can be used.

3.7 Examples

3.7.1 Calculate Noise Figure and Temperature from Output Noise Power

Consider an amplifier such as shown in Figure 3-3 with an available gain of $G_{dB} = 13$ dB, an output noise power of $N_{out,dB} = -160$ dBm in a 1 Hz bandwidth and an input noise temperature of $T_0 = 290$ K.

In a first step all logarithmic parameters (gain and output noise power) are converted to their linear values using equations (5) and (2), respectively:

$$G = 10^{(13/10)} = 19.95 \quad (41)$$

and

$$N_{out} = (0.001 \text{ W}) \cdot 10^{-160/10} = 1 \cdot 10^{-19} \text{ W}. \quad (42)$$

The input noise power of a noise source with noise temperature T_0 can be calculated using equation (19). For a bandwidth of $B = 1 \text{ Hz}$ the input noise power N_{in} is

$$N_{in} = N_0 = kT_0B = 1.38 \cdot 10^{-23} \cdot 290 \text{ W} = 4.00 \cdot 10^{-21} \text{ W} \quad (43)$$

Using equation (24) the noise power N_a added by the amplifier can be calculated as follows:

$$N_a = \frac{N_{out}}{G} - N_{in} = \frac{1 \cdot 10^{-19} \text{ W}}{19.95} - 4.00 \cdot 10^{-21} \text{ W} = 1.01 \cdot 10^{-21} \text{ W} \quad (44)$$

The noise factor is given by equation (27):

$$F = \frac{N_a}{N_{in}} + 1 = \frac{N_a}{N_0} + 1 = 1.25.$$

Converting the noise factor to the logarithmic noise figure:

$$NF = 10 \cdot \log(F) = 0.98 \text{ dB}. \quad (45)$$

And the equivalent noise temperature at the input of the amplifier is calculated by using equation (30):

$$T_e = T_0(F - 1) = 73.4 \text{ K}. \quad (46)$$

3.7.2 Calculate Noise Figure of a Cascade

Consider a cascade of two amplifiers according to Figure 3-5. The first amplifier has a gain of $G_{1,dB} = 20 \text{ dB}$ and a noise figure of $NF_1 = 2 \text{ dB}$. The second amplifier has a gain of $G_{2,dB} = 20 \text{ dB}$ and a noise figure of $NF_2 = 11 \text{ dB}$. If the input noise temperature of the cascade is T_0 equation (38) can be used to calculate to total noise factor. In a first step, all logarithmic parameters are converted to their corresponding linear values:

$$G_1 = G_2 = 10^{20/10} = 100, \quad (47)$$

$$F_1 = 10^{2/10} = 1.58 \quad (48)$$

and

$$F_2 = 10^{11/10} = 12.59. \quad (49)$$

Using equation (38) the total noise factor is

$$F_{total} = F_1 + \frac{(F_2 - 1)}{G_1} = 1.70. \quad (50)$$

The noise figure is

$$NF_{total} = 10 \cdot \log(F_{total}) = 2.31 \text{ dB}.$$

Note: The gain of the second stage does not influence the total noise figure. Additionally, the influence of the noise figure of the second stage is decreased by the gain of the first stage.

4 The R&S®ZNA Noise Figure Application

The R&S®ZNA K30 Noise Figure Application guides the user to create a noise figure channel, optimize the available hardware and software settings, to calibrate the channel, and finally to make a noise figure measurement.

Several tools exist that allow the user to verify that the channel is operating in a linear region, with good signal to noise ratio in the measured quantities. Alternatives are provided for cases where the DUT is challenging due to a very low noise figure, low gain, or even high gain.

A Quickset Wizard has been included in the K30 Noise Figure Application, and the Quickset Wizard supplies most of the guidance regarding optimal settings. The concept is to describe the key specifications of the DUT, which are the nominal gain, nominal noise figure, and maximum “linear” input power which keeps the device away from gain compression.

In return for providing these three inputs, the K30 Quickset Wizard will take care of the power levels both during calibration and measurement, ensuring that both the DUT and the R&S®ZNA receivers stay out of compression. Further, the Quickset Wizard suggests the optimal hardware settings which provide the best signal to noise ratio during the measurement, which also leads to the shortest measurement time.

But there are always competing requirements that may prevent the use of the optimal hardware settings. In this case the Quickset Wizard accommodates the restrictions, and offers the optimal solution among the remaining settings.

4.1 Required Equipment and Options

Figure 4-1 shows a common setup for making a noise figure measurement with the R&S®ZNA vector network analyzer. The required equipment is a vector network analyzer, a power sensor and the calibration standards, which are most conveniently provided with a USB based automatic calibration unit. An alternative to the USB based automatic calibration unit is a manual calibration kit. Further, a 50 Ω termination will be required for the receiver noise calibration.

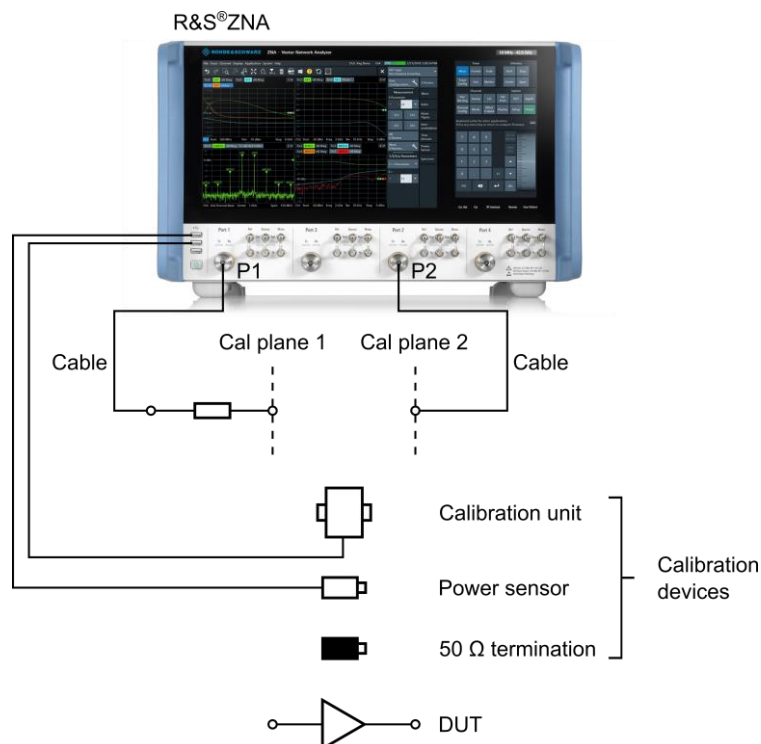

Figure 4-1: Typical R&S®ZNA setup for measuring noise figure

Overview of required equipment:

- ▶ R&S®ZNA vector network analyzer
- ▶ USB based R&S automatic calibration unit -OR- manual calibration kit
- ▶ USB based R&S power sensor
- ▶ 50 Ω termination
- ▶ (typically) two RF cables
- ▶ (typically) a 3 dB, 6 dB or 10 dB external, well matched attenuator placed at the end of the input cable

The required options on the R&S®ZNA include:

- ▶ Option K30: the noise figure application
- ▶ Option B16: Direct receiver access
- ▶ Option B21: Port 1 source attenuator
- ▶ Option B32: Port 2 measurement receiver attenuator
- ▶ Option B302: Port 2 low noise amplifier

In addition, the following options are highly recommended, as they are often used during noise figure measurements:

- ▶ Option B161: Port 1 source monitor
- ▶ Option B31: Port 1 measurement receiver attenuator
- ▶ Option B501: Port 1 isolation amplifier

The available hardware options and their benefits are described in detail in chapter 5.

4.2 Setup a Noise Figure Channel

The following example demonstrates how to measure the noise figure of an amplifier. The amplifier used in this measurement has approximately 21 dB of gain and a noise figure of about 1.6 dB in the frequency range of 1 GHz to 6 GHz.

4.2.1 Configure the Noise Figure Channel

First disconnect any device that is connected to the ZNA ports that could be damaged by the output power of the R&S®ZNA after preset. Then, according to Figure 4-2, follow steps 1 to 5 to set up a noise figure channel:

1. Preset the R&S®ZNA.
2. Press the *Meas* key.
3. Select *S-Params*.
4. Select the *Noise Figure* tab.
5. Press the *Noise Figure...* button.

The main window of the noise figure setup opens (Figure 4-3). In this window the user can define different settings such as measurement frequencies, base power or noise bandwidth. Further, in the frame *Meas and Cal Settings* (Figure 4-3) the user will be directed to the *Quickset...* dialog, the *Advanced Settings...* or the *Calibration Settings...* via the corresponding buttons. In this example, the Quickset dialog will be used to find the optimum measurement and calibration settings.



Figure 4-2: Configure a noise figure channel

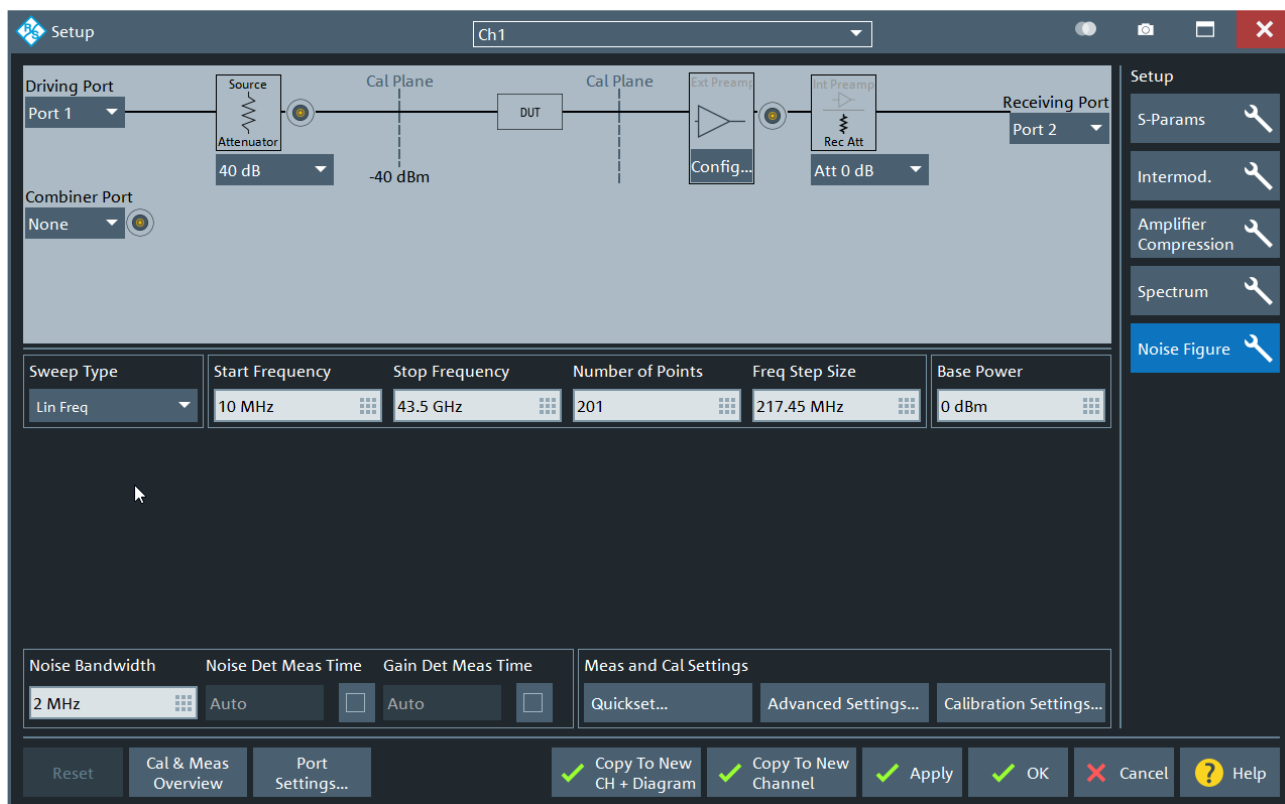

Figure 4-3: Main window of noise figure setup

4.2.2 Enter Measurement and DUT Settings

In the Quickset dialog (Figure 4-4), settings such as measurement frequencies, DUT settings and R&S®ZNA hardware settings can be defined to find an optimized setup with respect to measurement time, power levels or trace noise. With steps 6 to 8 the user can define the measurement frequency setup:

6. Enter the start frequency.
7. Enter the stop frequency.
8. Enter the number of sweep points.

Steps 9 to 11 define the DUT characteristics based on which the power levels will be set and a proposal for the R&S®ZNA hardware settings is suggested:

9. Enter the approximate gain of the amplifier (in this example, 21 dB).
10. Enter the approximate noise figure of the amplifier (in this example, 1.6 dB).
11. Enter the maximum input power to the amplifier (in this example, -30 dBm) to ensure the amplifier will not be operated in compression.

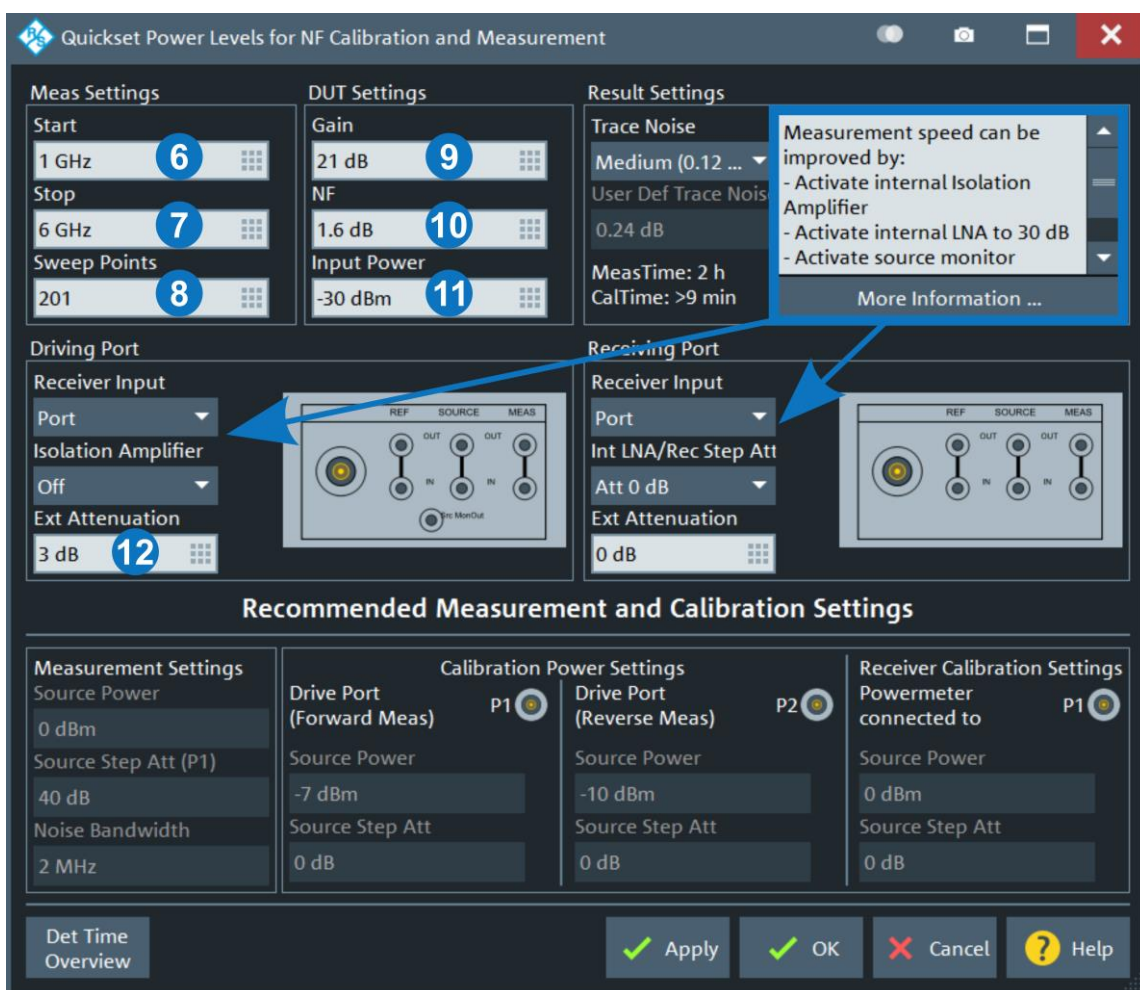

Figure 4-4: Quickset dialog for noise figure setup

An external attenuator can be used to improve the source return loss presented to the DUT input. Its value can be defined in the *Driving Port* frame in the *Ext Attenuation* field:

12. Define the external attenuator (in this example, 3 dB).

Without good source port match the noise figure result might show a ripple that can be minimized by increasing the value of the external attenuator at the DUT input port.

4.2.3 Select the Hardware Configuration

At this point, as can be seen in the upper right-hand corner of the dialog box, the Quickset Wizard recommends hardware settings to optimize the measurement time for this DUT. Select the settings that will be utilized in this setup (Figure 4-5):

13. Select *Source Monitor* on port 1.
14. Enable the isolation amplifier on port 1 (30 dB).
15. Select *Reverse Coupler* on port 2
16. Enable the pre-amplifier on port 2, with *Gain 30 dB*.

4.2.4 Select the Desired Trace Noise

Now observe the estimated measurement time and calibration time for this setup. Adjust the allowed trace noise in order to increase or decrease the measurement and calibration times.

17. In this example the *Medium* trace noise setting has been selected (Figure 4-5).

Trace noise is a stochastic deviation from a mean value that can be reduced by increasing the detector times (section 4.5.1). The Quickset Wizard will set the detector times based on the selected trace noise value.

The *More Information ...* button will provide details about the various setups and the corresponding calibration times and measurement times.

Note: The estimated calibration and measurement times depend on the R&S®ZNA type that is used. For example, the calibration and measurement times could vary between the R&S®ZNA26 and the R&S®ZNA43.



Figure 4-5: Proposed R&S®ZNA hardware settings in the quickset dialog

4.2.5 Compare Quickset Proposal with the Physical Setup

At this point, the R&S®ZNA has all the information required for a noise figure calibration and measurement. This is the best time to check that the front panel connectors have been configured to match the selected settings in the Quickset dialog (Figure 4-5). For example, a port 1 connector needs to be re-positioned to enable the source monitor connector. And on port 2, there are two connectors that need to be re-positioned to reverse the port 2 coupler.

Finally, make sure the external attenuation entries match the actual attenuator values that are being used at the ends of the cables.

Then close the Quickset dialog box and the main window of the noise figure settings by clicking the “OK” button.

4.3 Calibrate the Noise Figure Channel

The calibration process is needed to correct for the error terms of the VNA (section 4.3.1), determine the absolute power levels at the VNA ports (section 4.3.2), measure the noise contribution of the receiver (section 4.3.3) and compensate for sideband noise contributions (section 4.5.3.1).

The noise figure channel will accept any full two port calibration or a “One Path Two Ports” calibration depending on the calibration kit that is used. In this example, a full two port calibration will be performed using a USB based automatic calibration unit, a USB based power sensor and an additional 50 Ω load.

Plug both of the USB calibration devices into the USB ports of the R&S®ZNA. In the main menu of the R&S®ZNA (Figure 4-6) perform the following steps to define the desired calibration:

1. Press the *Cal* button.
2. Select the *Configure/Start Calibration... key*.



Figure 4-6: Start NF calibration

In the tab *Calibration Type* of the calibration main menu (Figure 4-7) the calibration type, the power meter and the Calkit/CalUnit can be selected in the table *Cal Settings*. Additionally, in the row *Rcv Power Cal* the port at which the power calibration will be performed can be selected. This is automatically done based on the hardware setup chosen in the Quickset menu. In this example, the power calibration will be performed at port 2 which is usually the choice when source monitor at port 1 is selected.

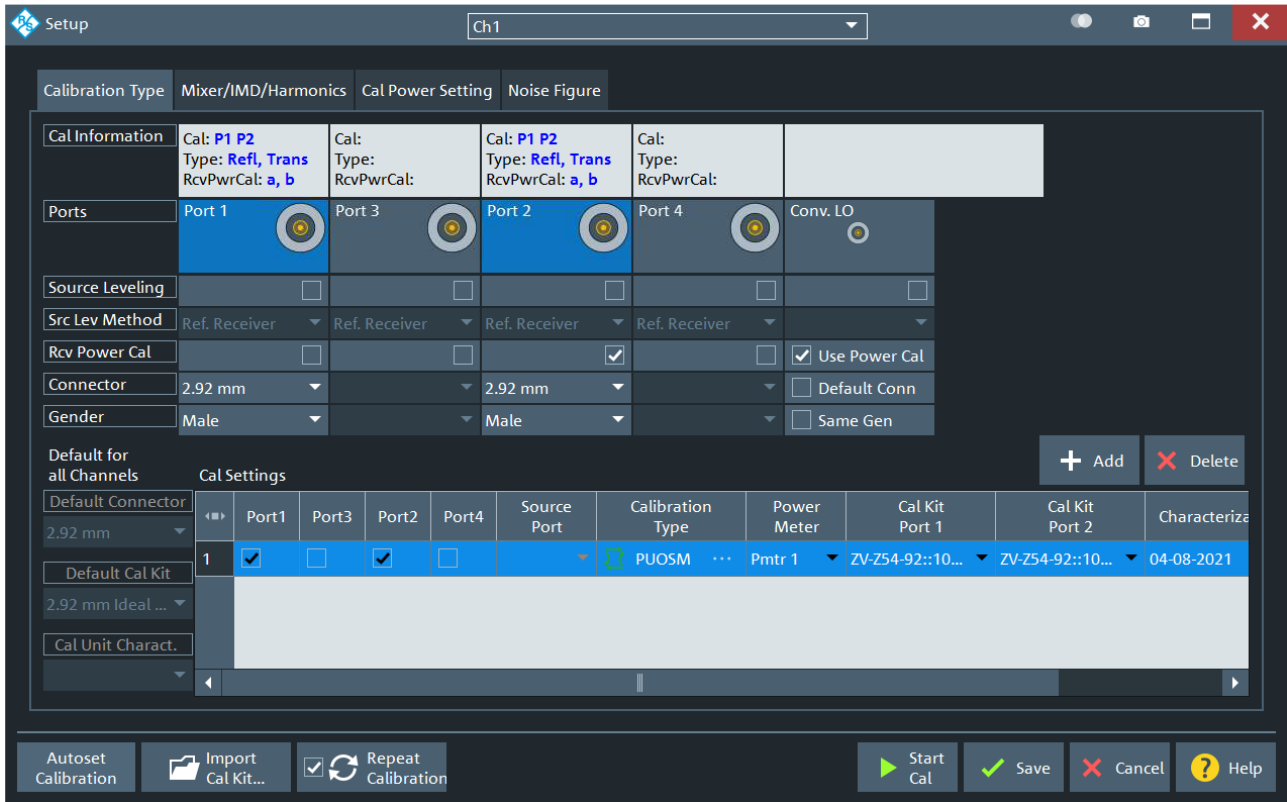

Figure 4-7: Calibration type menu

In the tab *Noise Figure* the calibration power settings can be modified. However, the Quickset values are optimized as long as the DUT parameters have been defined properly in the Quickset dialog; and care is required if these values are changed.

If everything is set up correctly and the calibration devices are connected press the *Start Cal* button. In the following sections the three steps that are performed for an NF calibration are described in detail.

4.3.1 S-Parameter Calibration

In the first step an S-parameter calibration will be performed. The graphic of Figure 4-8 will be displayed in the R&S®ZNA window. Perform the following steps:

3. Connect port 1 and port 2 cables to the corresponding ports of the calibration unit.
4. Press the *Start Cal Sweep* button.

After the calibration measurements of step 1 are finished the application will automatically proceed to step 2.

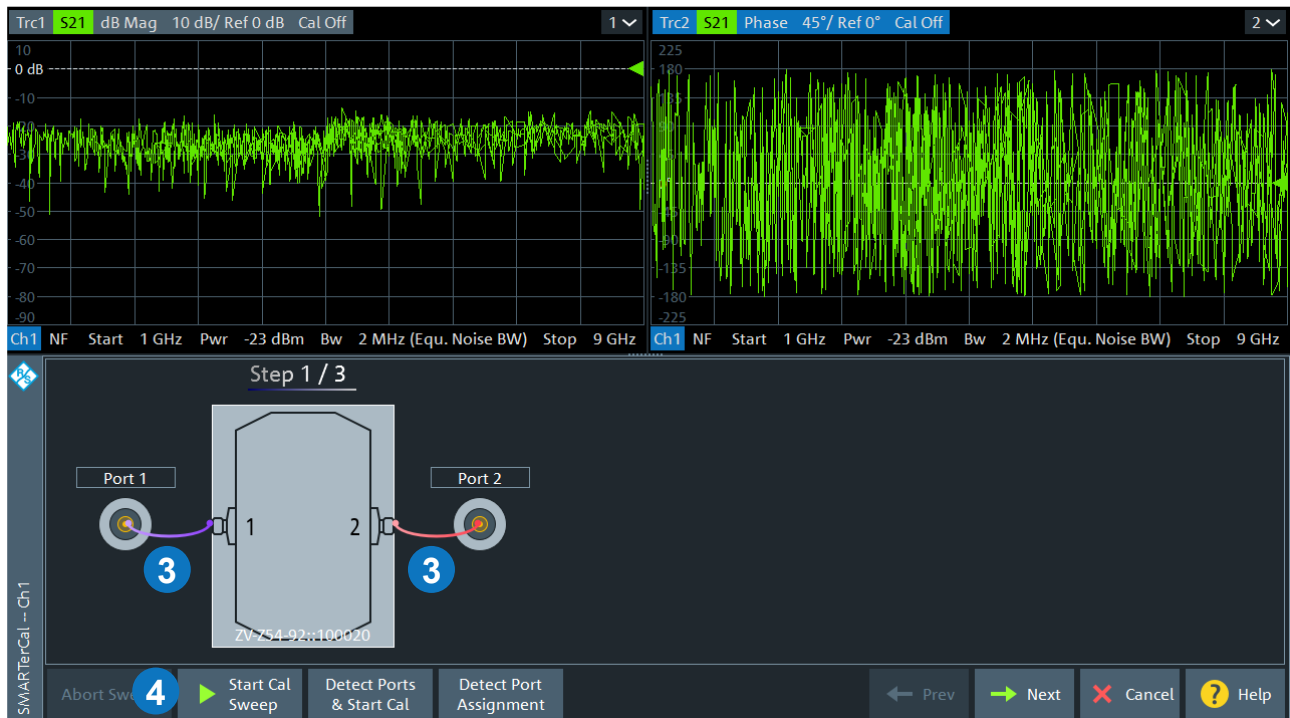

Figure 4-8: S-parameter calibration of the noise figure channel

4.3.2 Power Calibration

Step 2 is a power calibration step.

Note: A limiting factor for the accuracy of the NF measurement is the accuracy of the power meter measurement during calibration. The accuracy of the power meter should be higher than the desired accuracy of the NF measurement. Care has to be taken in the choice of the power meter for the setup with source monitor. In this case, the power calibration will be performed at port 2 and the available power during calibration could be too low (< -30 dBm) for some power sensors.

Based on the hardware settings defined in the Quickset dialog and the calibration type that will be used the port where the power meter has to be connected to can be port 1 or port 2 (the “One Path Two Ports” calibration always requires the power meter to be connected to port 1). Make sure that it is connected to the port that is displayed in the graphic of the step 2 on the R&S®ZNA screen (Figure 4-9):

5. Connect to the power sensor to the port as described on the R&S®ZNA screen.
6. Press the *Start Cal Sweep* button.

After the power meter measurement is finished the calibration will proceed with step 3.



Figure 4-9: Power calibration of the noise figure channel

4.3.3 Receiver Noise Calibration

In the third calibration step, a 50 Ω load needs to be connected to port 2 for calibrating the receiver's noise contribution. According to Figure 4-10 perform the following steps:

7. Connect a 50 Ω load to the port 2 calibration plane.
8. Press the *Start Cal Sweep* button.

After the sweep is finished and all three calibration steps were successful, an *Apply* button should be active. Pressing this button will conclude the calibration and apply the calibration data to the noise figure channel.



Figure 4-10: Receiver noise calibration of the noise figure channel

4.4 Measure the DUT

Connect the DUT, apply DC power, and measure its noise figure.

Note: Some DUTs might need a warmup time before they are in a thermal steady state. During warmup, the noise figure might change. Make sure that the DUT is in a steady state for repeatable measurements.

The measured noise figure of the example DUT is shown in Figure 4-11. It starts at about 1.2 dB at 1 GHz and increases to about 1.8 dB at 6 GHz. The default trace that is displayed after the calibration is the noise figure trace *NF21*.

The noise figure channel provides the following four measurement parameters:

- ▶ Noise figure of the DUT: *NF21* for port 1 as driving port and port 2 as receiving port,
- ▶ gain of the DUT: $b2/a1(P1)$ for port 1 as driving port and port 2 as receiving port,
- ▶ noise figure of the receiver: *NF2R* for port 2 as receiving port, and
- ▶ noise density at the receiving port: *ND2* for port 2 as receiving port.

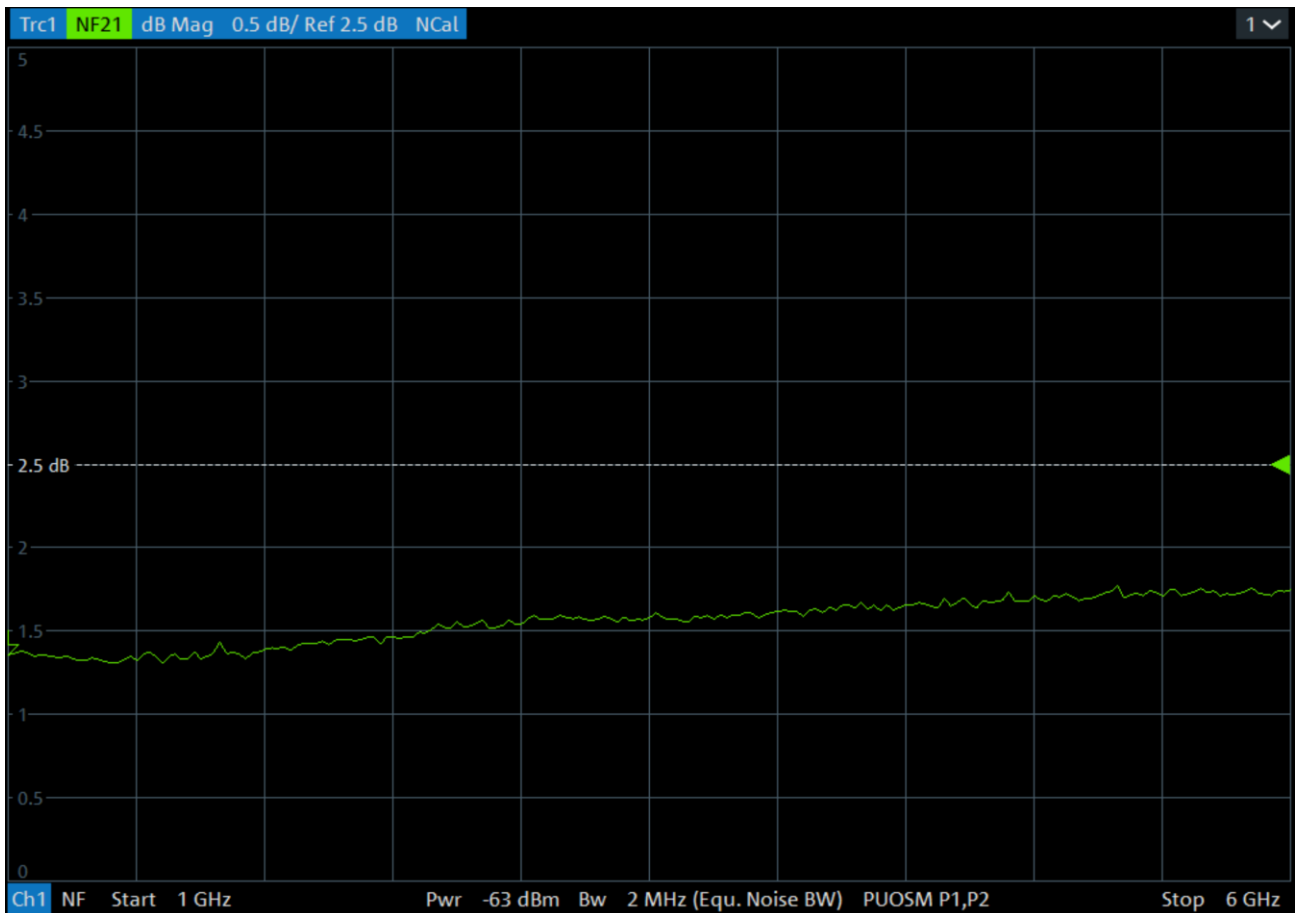

Figure 4-11: Noise figure result of the example DUT

To display any of these results, either go to the *Meas* -> *Noise Figure* menu and drag the desired measurement parameter to the position where a new window should be displayed (Figure 4-12), or you can add a trace in an existing diagram or a new diagram plus trace via the *Trace Config* menu.

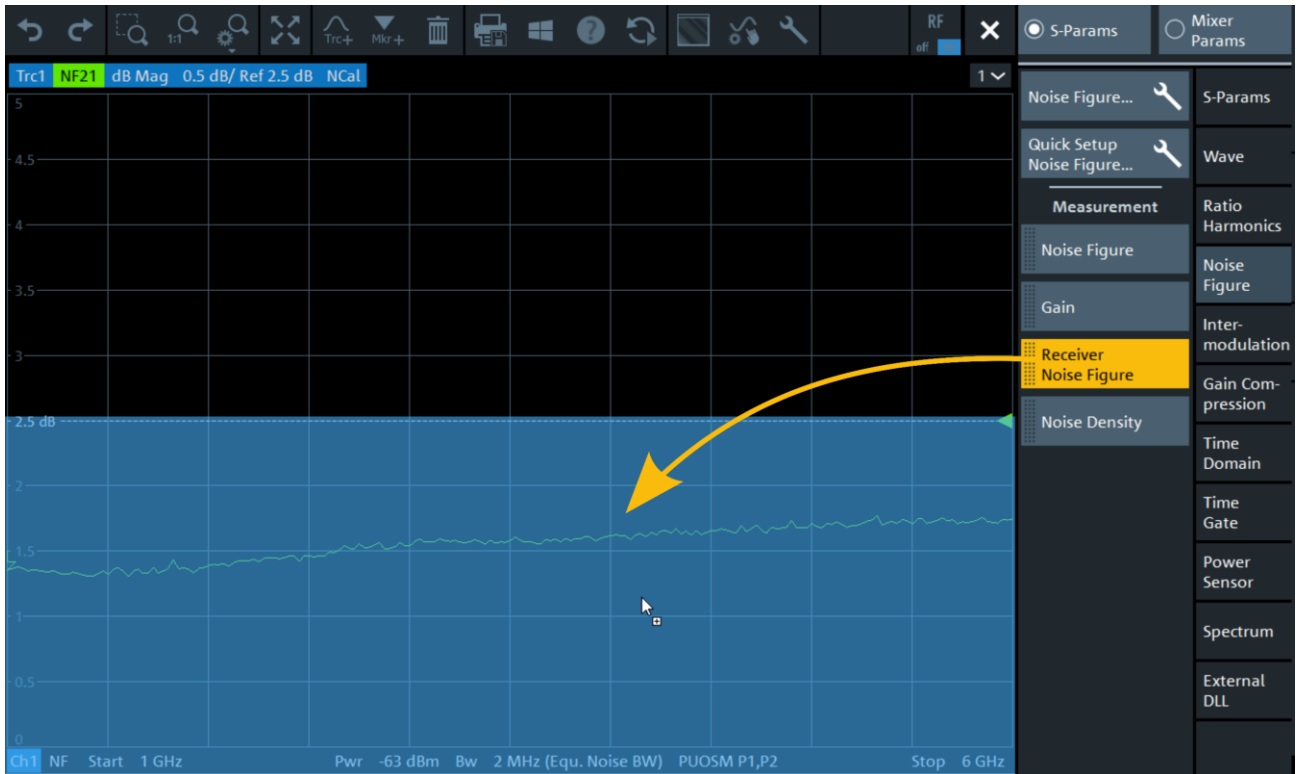

Figure 4-12: Dragging a measurement result into a new window

In Figure 4-13 all four measurement parameters are displayed in separate diagrams.

As a rule of thumb, the noise figure of the DUT (in this example Trc1) and its gain (in this example Trc3) added together in the logarithmic domain (dB) should exceed the noise figure of the receiver. In the diagram 2 of Figure 4-13 is the sum of DUT noise figure and gain displayed (Trc1 + Trc3) as Trc5. This can be done in the *Trace Config* menu via the tab *Math* by clicking the *Define Math...* button in the *Formatted Data* area (Figure 4-13). For a desired noise figure accuracy, the measurement time will be shorter for higher offsets between receiver noise figure (in this example Trc2) and the sum of DUT noise figure and gain (in this example Trc5).

If the gain + NF of the DUT is about equal to the receiver's noise figure, the measurement can still be accomplished. But it will involve more averaging and longer detector times, in order to average out the receiver's noise contribution. And the results will contain more trace noise.

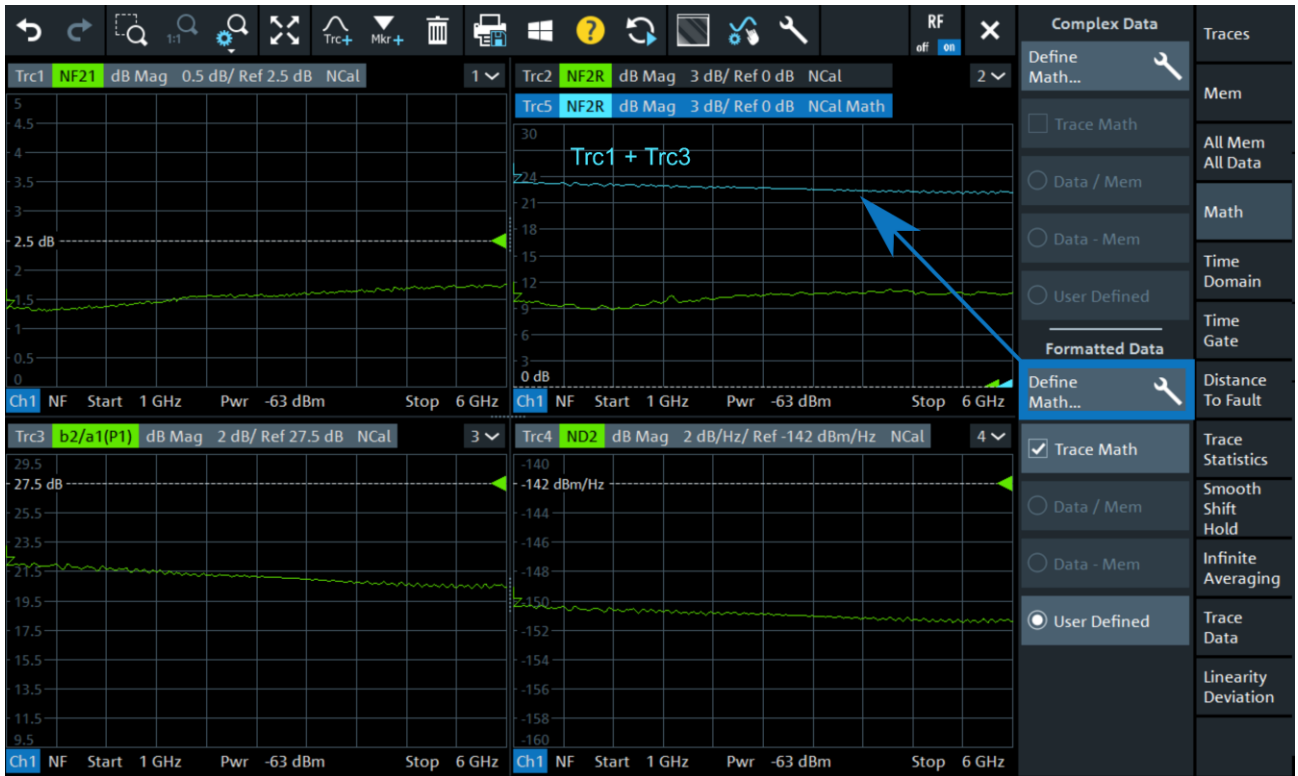

Figure 4-13: Measurement results of the example DUT

4.5 Measurement Improvements

4.5.1 Detector Times

Based on the DUT and trace noise settings, the Quickset Wizard calculates the required detector times for the noise and the gain measurement. In the main window of the noise figure settings (Figure 4-3) the detector times will be set to “Auto” in this case. If shorter or specific detector times are requested by the user they can be set here. Choosing shorter detector times than proposed by the Quickset Wizard will result in higher trace noise. The trace noise could be partly reduced by using averaging which is described in section 4.5.2

4.5.2 Averaging

4.5.2.1 Channel Averaging

Using averaging in addition to short detector times for the DUT measurement has the advantage of quickly getting the results displayed while the trace noise is reduced over time as the sweep repeats. For activating averaging go to the menu *Pwr Bw Avg* and check the *On* button in the *Average* tab.

Note: Channel averaging will only have an effect if the phase mode Coherence On is selected in the Mode menu which is the default setting in a noise figure channel.

4.5.2.2 Trace Averaging

An alternative to channel averaging is infinite trace averaging. Activate this mode with the following steps:

- ▶ Press the *Trace Config* button.
- ▶ Then select the *Infinite Averaging* tab.

- Enable averaging by checking the *Infinite Average* button.

Now the results can be observed while the measurement converges.

4.5.3 Advanced Settings

4.5.3.1 Sideband Correction

The R&S®ZNA receivers are optimized for precision S-parameter measurements. In general, this means they do not contain pre-selection filters or image rejecting filters, as these filters have a negative impact on S-parameter measurement uncertainty, and they are not needed. Therefore, not only signal contributions of the desired RF frequency are converted to the IF frequency of the R&S®ZNA but also image frequencies and contributions of higher order harmonics as shown in Figure 4-14.

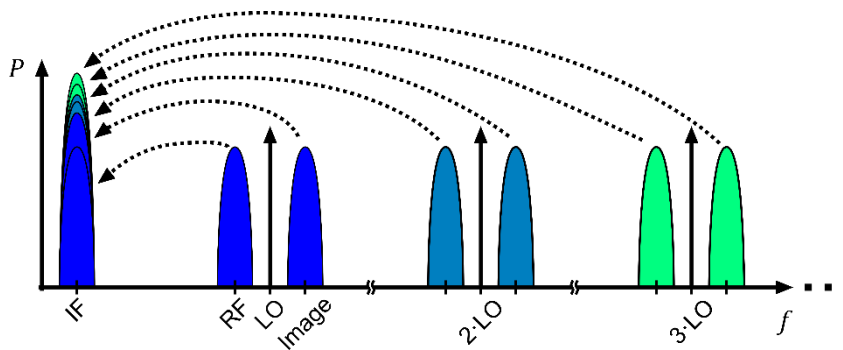

Figure 4-14: Schematic sideband conversion

The noise contribution of sideband reception is dependent on the gain of the DUT at these sideband frequencies. Figure 4-15 shows the sensitivity of the receiver at the fundamental RF frequency ($n = 1$), around the second harmonic $2 \cdot LO$ ($n = 2$) and around the third harmonic $3 \cdot LO$ ($n = 3$).

Now, consider a narrow-band DUT that is measured at an RF frequency of 1 GHz. For the narrow-band DUT with no gain at the second and third harmonic (Figure 4-15 a)), there will be no significant noise contribution from these higher frequencies. Therefore, sideband correction is not required.

However, if the DUT has significant gain around multiples of the LO frequency (Figure 4-15 b)) the noise contributions at these frequencies cannot be neglected.

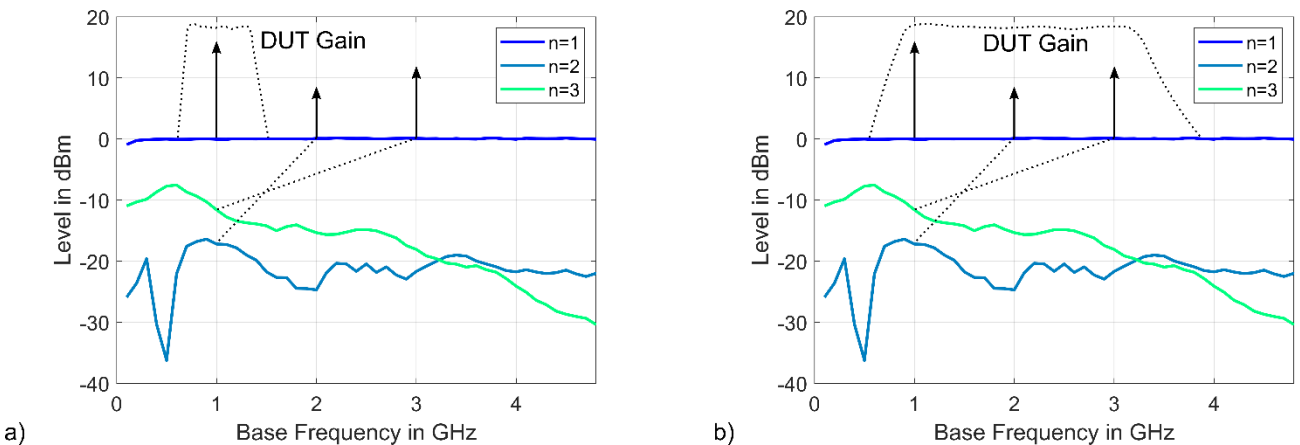

Figure 4-15: Sideband contributions: a) Narrow-band DUT, b) broad-band DUT

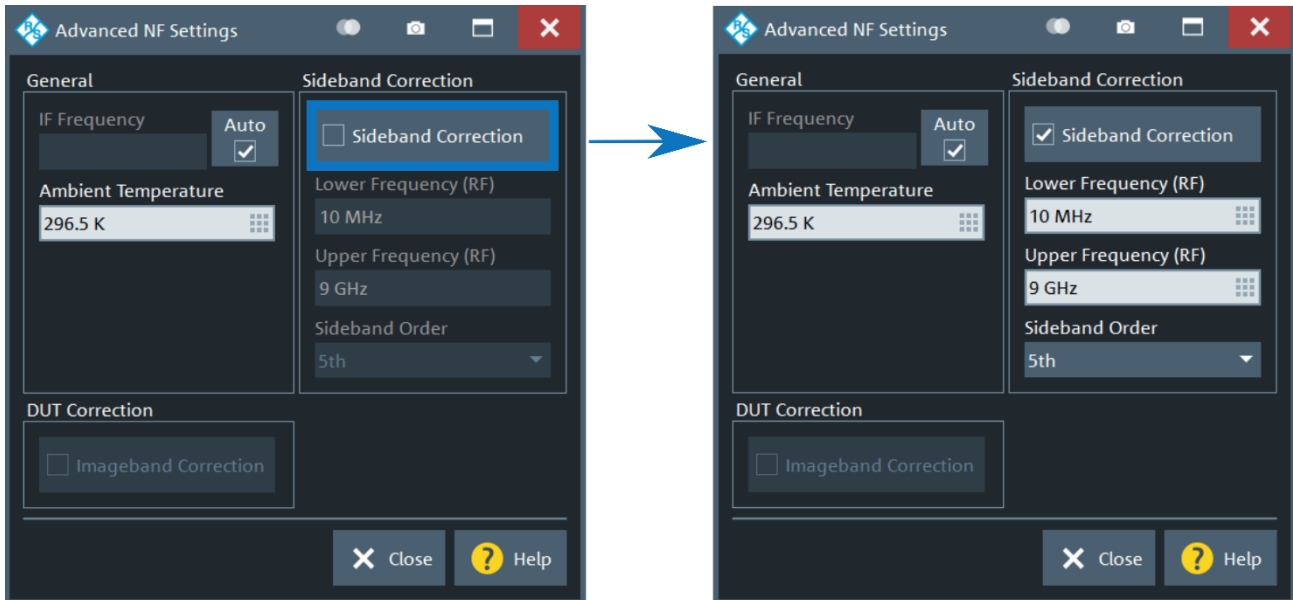

Figure 4-16: Setup of the sideband correction

In the noise figure channel, an error correction algorithm is utilized to compensate for the noise contributions at those sideband frequencies. This algorithm can be adjusted by pressing the *Advanced Settings...* button in the noise figure main dialog of Figure 4-3. To activate the algorithm, check the *Sideband Correction* box as shown in Figure 4-16. Now, the following parameters can be set:

- ▶ *Lower Frequency (RF)*
- ▶ *Upper Frequency (RF)*
- ▶ *Sideband Order*

In this example, the upper frequency up to which the sideband correction will be calculated is 9 GHz and the sideband order is set to the 5th harmonic. This means that for a fundamental RF frequency of 1.8 GHz (9 GHz/5) the contribution of all harmonics up to the fifth order will be compensated. Between 1.8 GHz and 2.25 GHz (9 GHz/4), the contribution of all harmonics up to fourth order will be compensated. Between 2.25 GHz and 3 GHz (9 GHz/3), the contribution of all harmonics up to third order will be compensated. If the DUT has no gain above 5 GHz, then the upper frequency can be set to 5 GHz. The result will be a faster measurement

If the noise contribution at harmonic frequencies is not known before the measurement the sideband correction could be set to a higher order (maximum 10th order) with an upper frequency that exceeds the desired frequency range. This setup has to be defined before the calibration process and will increase calibration and measurement time. After an NF measurement has been acquired with sideband correction, the trace can be stored in memory and the measurement can be repeated with reduced order or without sideband correction. This approach can be used to find the required order and upper frequency. If the sideband order or the upper frequency of sideband correction is reduced in a previously calibrated noise figure channel the channel does not need to be calibrated again.

As can be seen in Figure 4-15 b), the third order harmonic for RF frequency of $f_{RF} = 1$ GHz is at about -12 dB. This means that a DUT that is measured at $f_{RF} = 1$ GHz and that has significant gain at $f = 3 \cdot 1 \text{ GHz} = 3$ GHz the contribution of the third harmonic probably cannot be neglected. In this case, the sideband order should be set to at least 3 and the upper frequency to at least 3 GHz.

The noise figure measurement result of the example DUT are shown in Figure 4-17 for the two cases with and without sideband correction. In this case, the highest impact of the sideband correction can be observed at 1 GHz and decreases at higher frequencies. For this specific DUT the sideband contribution above 3 GHz can be neglected.



Figure 4-17: Comparison of NF with and without sideband correction

4.5.3.2 Ambient Temperature

Ambient temperature is another advanced setting. This is the temperature of the external elements between the R&S®ZNA test port and the DUT. For example, the cable and an external attenuator that are used to connect R&S®ZNA Port 1 to the input of the DUT.

In general, these external interconnect elements have resistive loss. That means that they are also contributing noise to the input of the DUT, following the $kT_{in}B$ formula. In order to account for the noise contribution from these external components, the noise figure algorithm needs to know the temperature of these elements.

Typically, this is the ambient temperature of the room where the test is being performed. The default value is 296.5 K.

- 296.5 K = 23.35°C
- 296.5 K = 74.03°F

Keep in mind that this setting is *not* the physical temperature of the DUT but the temperature of the passive devices at port 1 such as cables and the external attenuator.

Note that an external attenuator can warm up significantly if directly connected to a DUT that is at high temperature. The accuracy of the NF results depends on how well the actual input noise temperature is described by the value *Ambient Temperature*.

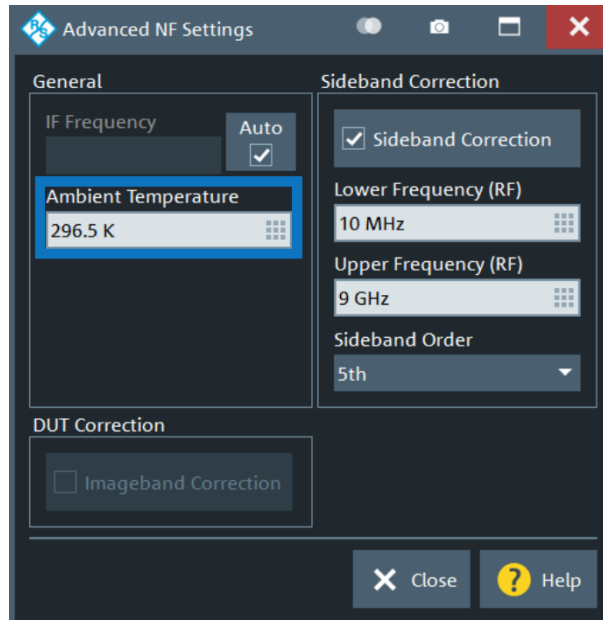

Figure 4-18: Ambient temperature setup

4.5.4 Check for Compression

The Quickset algorithm, when armed with the proper information, will configure the noise figure channel in a way that avoids compression at all times, during calibration and during measurement of the DUT.

However, it is easy to verify that everything is operating in a linear region by stepping the power up and down by a few dB during the measurement. For example, the power can be stepped up and down by 5 dB, to confirm that the NF results do not change.

For our example DUT, the power could be increased by 5 dB (to -58 dBm) from the nominal value of -63 dBm, and the result is saved to memory. Then the power is stepped down 5 dB (to -68 dBm) from the nominal value, and a second trace is saved to memory. Finally, the power is returned to the nominal value of -63 dBm. If all three curves are well aligned compression is not an issue for any of the three input power values.

During this test, it will become apparent that the displayed power at the bottom of the screen is the base power of the channel not including the value of the source step attenuator.

To display the value including the step attenuator, press the Start button, then select Port 1 from the pull-down menu (Figure 4-19).

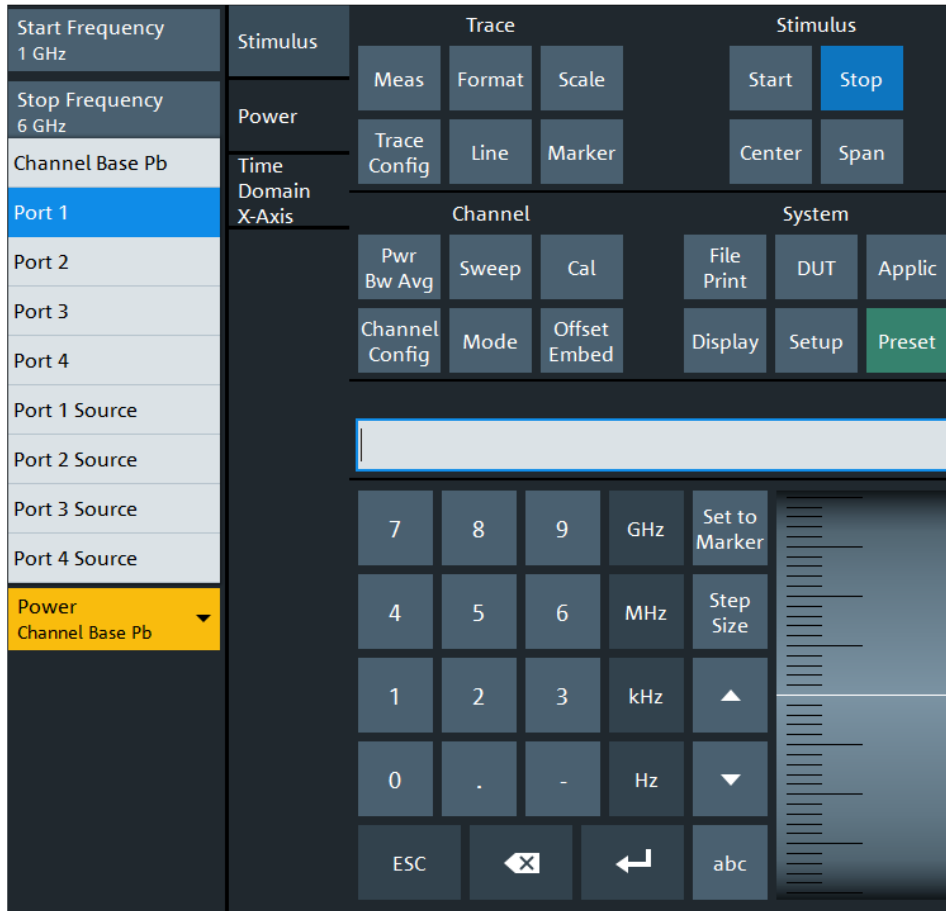

Figure 4-19: Display channel power including value of source step attenuator

5 Hardware Options for NF Measurements

In this chapter, the available hardware options at the driving and the receiving port are discussed that can be used to improve different parameters of the noise figure measurement. Which hardware option to use for a specific setup depends on the DUT, the required accuracy and the desired measurement speed. Following the Quickset approach of section 4.2, the application will propose the required hardware options for improvement of the measurement speed based on the defined setup.

The hardware options that are used to set up or improve a noise figure measurement are listed in Table 1. Some hardware options are only available at certain ports, e.g. the low noise amplifier (option B302) will only be available at port 2. So, for optimized receiver noise figure port 2 is the recommended receiving port. Further, the driving port is required to be equipped with a source step attenuator option (available at all ports) and in some cases with a source monitor access which is only available at port 1 and 3. Further details for which DUTs and noise figure setups a particular option can be utilized are given in sections 5.1 and 5.2.

Typically, port 1 or 3 will be chosen as driving ports and port 2 will be chosen as receiving port. Although other combinations might be possible. In the hardware option figures of sections 5.1 and 5.2, port 1 will be regarded as the driving and port 2 as the receiving port.

The option B16 provides direct source and receiver access at all ports. This option is required for the source monitor access option (section 5.1.2), a reversed coupler setup for improved receiver sensitivity (section 5.2.3) and for setups with an external low-noise amplifier (section 5.2.4).

Table 1: Hardware options for noise figure measurements

Hardware Option	Designation of Hardware Option			
	Port 1	Port 2	Port 3	Port 4
Direct Source and Receiver Access	B16	B16	B16	B16
Source Step Attenuator	B21	B22	B23	B24
Receiver Step Attenuator	B31	B32	B33	B34
Source Monitor Access	B161	n.a.	B163	n.a.
Low Power Spurious Reduction	B501	n.a.	n.a.	n.a.
Low-Noise Amplifier	n.a.	B302	n.a.	n.a.

5.1 Port 1 Hardware Options

The available hardware options at port 1 are shown in Figure 5-1. Some of these options are also available at other ports. The options are designated as follows:

- ▶ B16: Direct source and receiver access (regards all ports)
- ▶ B21: Source step attenuator at port 1 (port 2: B22, port 3: B23, port 4: B24)
- ▶ B31: Receiver step attenuator at port 1 (port 2: B32, port 3: B33, port 4: B34)
- ▶ B161: Source monitor access at port 1 (port 3: B163)
- ▶ B501: Low power spur reduction amplifier at port 1

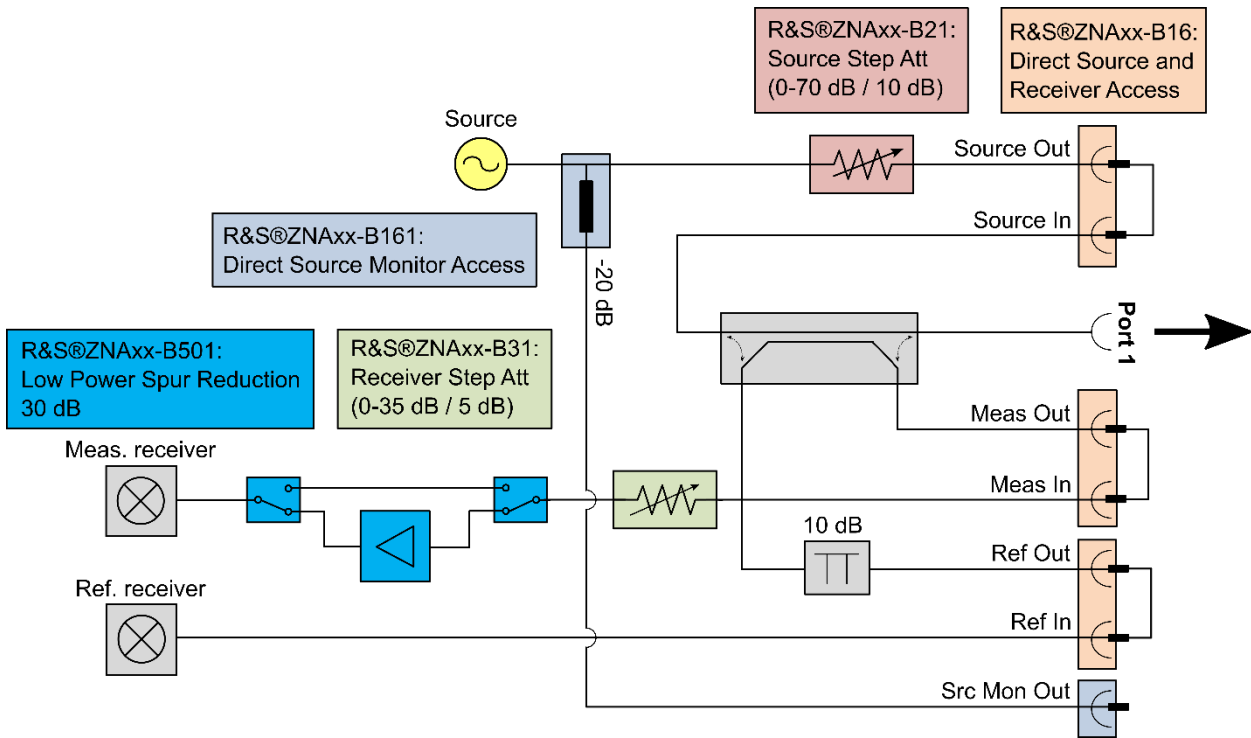

Figure 5-1: Hardware options at port 1

5.1.1 B21 Source Step Attenuator

- ▶ Goal: Provide defined noise source for noise measurement.
- ▶ DUTs: All kinds of DUTs.

The R&S®ZNA provides a terminated source impedance to the DUT, which also sources input noise to the DUT. The source step attenuator plays a key role in the noise measurement step. It is set to a high value (typically ≥ 40 dB) during noise measurements. A 40 dB setting attenuates all earlier sources of thermal noise to a negligible level. And it creates its own thermal noise with a power $kT_{att}B$, where T_{att} is the temperature of the internal B21 step attenuator. The R&S®ZNA monitors this temperature with internal temperature sensors, so the level of the input noise to the DUT is known.

This value is corrected such that the noise figure calculation is performed using the IEEE definition for noise figure, with an input noise temperature of $T_0 = 290$ K.

Note: The attenuator needs to be set to a value of 40 dB or higher for noise measurements in order to become the dominate source of thermal noise. Therefore, care is required if a value of < 40 dB is utilized.

Further, a large amount of external loss will also impact the amount of input noise presented to the DUT. This is considered during the noise figure calculation, and a correction term is applied.

5.1.2 B161 Source Monitor Connection

- ▶ Goal: Increase of reference receiver sensitivity for low DUT input power.
- ▶ DUTs: High gain DUTs, low DUT input power, measurements below 1 GHz.

A simplified block diagram of the R&S®ZNA port 1 with source monitor active is shown in Figure 5-2. The configuration of the B16 option is shown in Figure 5-3.

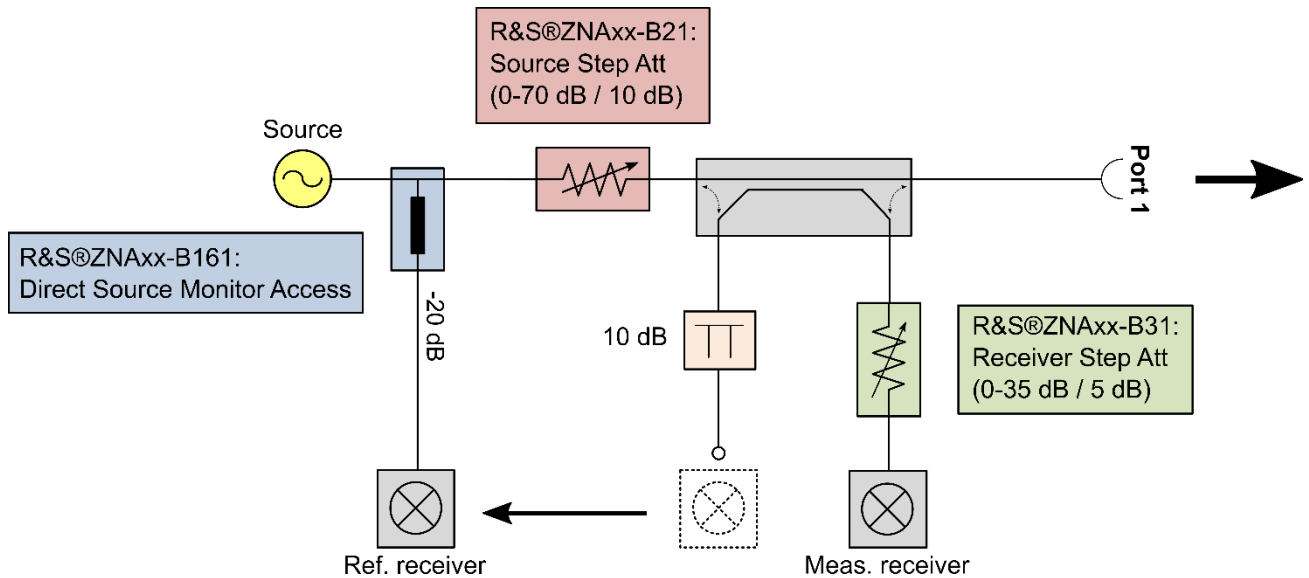

Figure 5-2: Simplified block diagram of active source monitor option at port 1

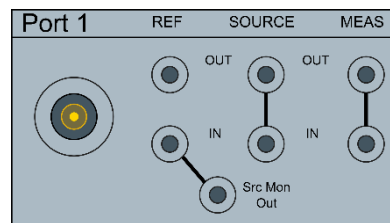

Figure 5-3: B16-configuration for accessing the source monitor at port 1

The source monitor option is available to provide a sample of the a-wave of port 1 to the reference receiver prior to the source step attenuator block. This improves the sensitivity on the a-wave in case the source step attenuator is used. When the source monitor connection is used, the reference receiver is effectively shifted to an earlier point in the port 1 block diagram, as shown in Figure 5-2.

If the DUT has a large amount of gain, and / or a very low input compression point, then the input power to the DUT needs to be set very low in order to prevent compression of the DUT or the port 2 receiver. Further, if the reversed coupler setup (section 5.2.3) at the receiving port is used in combination with the low-noise amplifier (option B302) the output power at the receiving port needs to be kept low to avoid receiver compression. Additionally, for frequencies below 1 GHz the loss of the coupler path of the reference receiver increases. So, for frequencies below 1 GHz using the source monitor can decrease measurement times by overcoming this increased coupling loss.

The Quickset dialog calculates the best input power setting for the DUT, as covered in section 4.2.3. And if the input power value is very low, then it recommends that the B161 source monitor connector should be used. This can reduce the measurement time significantly.

5.1.3 B31 Measurement Receiver Step Attenuator

- ▶ Goal: Increased sensitivity of the measurement receiver.
- ▶ DUTs: All kinds of DUTs.

The driving port measurement receiver is used to measure the b-wave. The b-wave is used during the measurement of the device's input return loss. The input return loss is used for mismatch correction in the noise figure calculation. The challenge occurs with the input signal to the DUT is at a low value. Then the measurement receiver needs to detect an even lower reflected signal. Without the measurement receiver step attenuator option, a 10 dB fixed attenuator will be installed.

The B31 step attenuator allows a setting of 0 dB which will improve the measurement receiver's sensitivity, resulting in a faster measurement. This is the typical setup for a noise figure measurement.

5.1.4 B501 Measurement Receiver Isolation Amplifier

- ▶ Goal: Increase of the sensitivity of the reflected wave at the driving port.
- ▶ DUTs: High gain DUTs, low DUT input power.

The B501 isolation amplifier (Figure 5-1) works in conjunction with the B31 step attenuator. It can be activated when the input signal to the DUT is low, and it will further improve the sensitivity of the b-wave measurement at the driving port. Additionally, this amplifier suppresses the LO leakage at port 1 which can be as high as -60 dBm at some frequencies without option B501, and with option B31 step attenuator set to 0 dB. Depending on the measurement setup (DUT gain and LNA at port 2), the LO leakage could drive the DUT or the LNA into compression.

The Quickset function will recommend the best setting for the B501 isolation amplifier based on the user supplied specifications of the DUT.

5.2 Port 2 Hardware Options

Port 2 is typically the receiving port during a noise figure measurement as the internal low noise amplifier is only available at this port. There are a number of hardware options which can be utilized to improve the individual measurements that are required for a noise figure calculation. The available options at port 2 are shown in Figure 5-4. Some of these options are also available at other ports. The options are designated as follows:

- ▶ B16: Direct source and receiver access (regards all ports)
- ▶ B22: Source step attenuator at port 2 (port 1: B21, port 3: B23, port 4: B24)
- ▶ B32: Receiver step attenuator at port 2 (port 1: B31, port 3: B33, port 4: B34)
- ▶ B302: Low noise amplifier

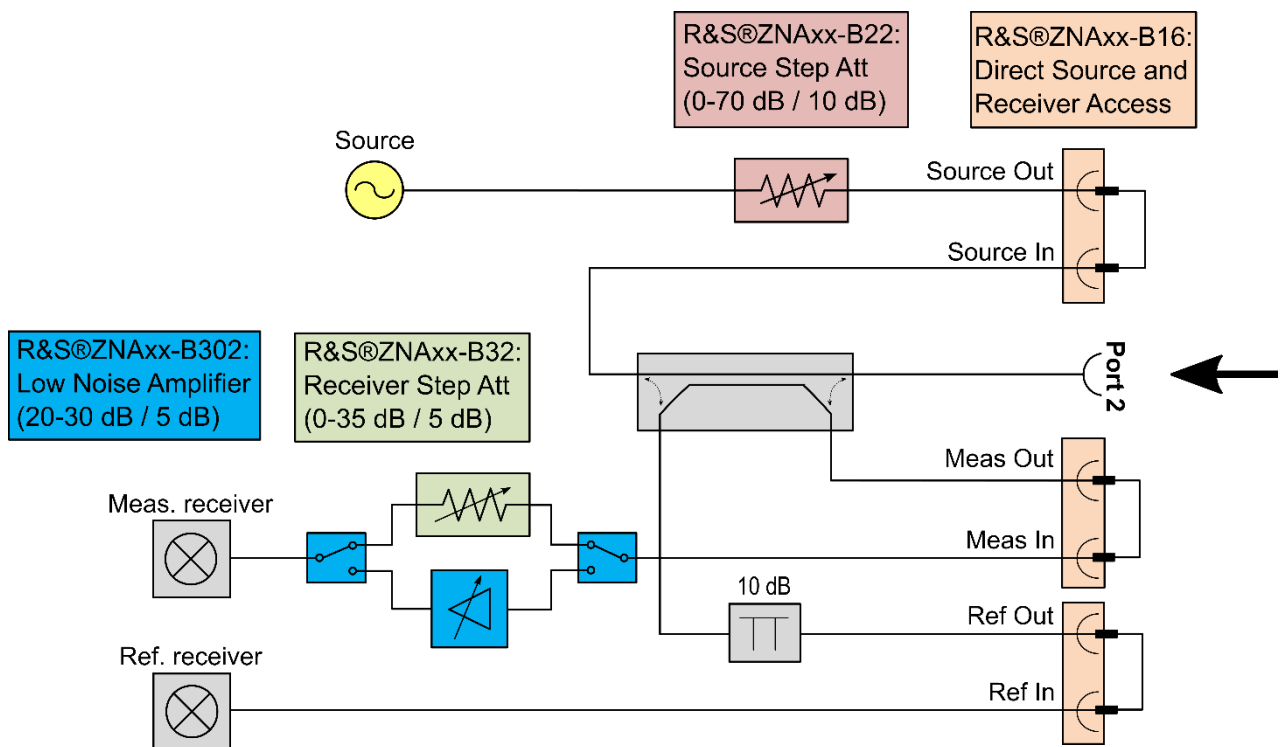

Figure 5-4: Hardware options at port 2

During the NF calibration and the NF measurement the measurement receiver of the receiving port is used to measure the b-wave at the receiving port to determine the following parameters:

- ▶ noise power when the receiver is terminated with a 50 Ω load (receiver calibration),
- ▶ noise power of the DUT measurement,
- ▶ transmitted power during the gain measurement of the DUT.

The b-wave during the gain measurement of the DUT is typically measuring a high-level signal at the output of the DUT. On the other hand, the measurement of the noise power at the output of the DUT is a more challenging measurement, since it requires a very sensitive receiver. So, most settings on port 2 are selected with the goal of improving the sensitivity of the receiver during the output noise power measurement.

In Figure 5-5 the noise figure of a R&S®ZNA67 receiver is shown for different setups. The setup with the highest receiver noise figure is the standard coupler (B16 option) configuration with receiver step attenuator set to 0 dB. Reversing the coupler will decrease the noise figure by about 10 dB. This option will be described in section 5.2.3. Further decrease of the receiver noise figure can be achieved over a broad frequency range by using the standard coupler configuration but activating the LNA (section 5.2.2). The best receiver noise figure result of Figure 5-5 can be reached with the reversed coupler configuration in combination with the LNA at 30 dB gain.

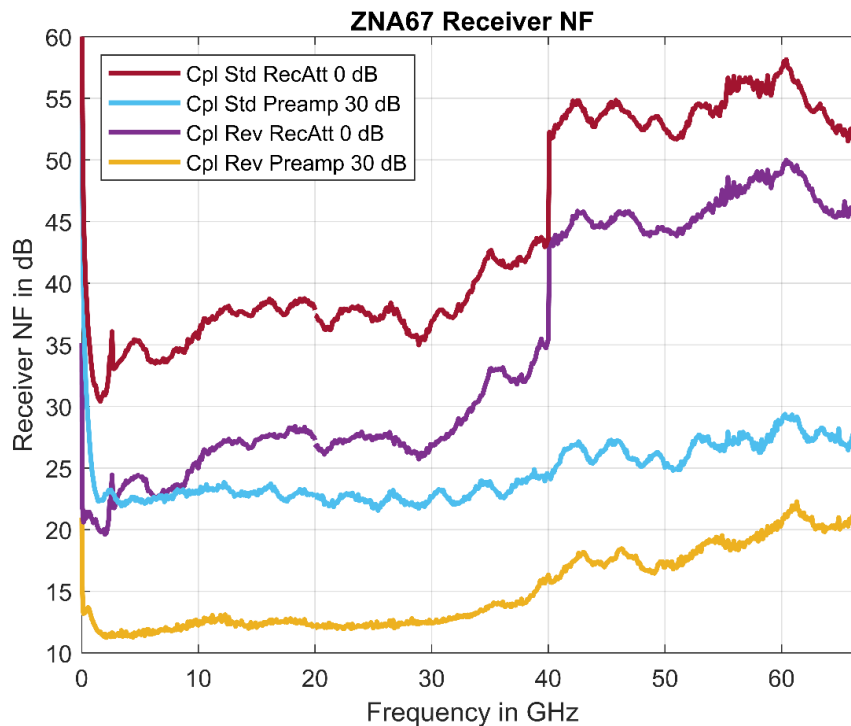

Figure 5-5: Receiver noise figure of the R&S®ZNA67 for different setups

5.2.1 B32 Measurement Receiver Step Attenuator

- ▶ Goal: Improve the noise figure of the receiver.
- ▶ DUTs: All kinds of DUTs.

Without option B32, a fixed 10 dB attenuator will be used in the measurement receiver path. To gain a higher sensitivity of the measurement receiver during the noise power measurements the B32 option allows this attenuation to be set to 0 dB. Further, using the internal low noise amplifier (section 5.2.2) will also require option B32 to be installed.

For very high gain DUTs (> 60 dB gain), setting this attenuator to a value ≥ 5 dB could improve measurement results.

5.2.2 B302 Low Noise Pre-Amplifier

- ▶ Goal: Increase sensitivity of the measurement receiver by decreasing its noise figure.
- ▶ DUTs: DUTs with low gain and low noise figure.

For DUTs that have low gain combined with a low noise figure, it might not be sufficient to set the B32 step attenuator to 0 dB. If even more sensitivity is required, then the B302 low noise amplifier can be activated. This low noise amplifier adds up to 30 dB of gain to the measurement receiver path, with the result of improving the receiver's noise figure by 10-20 dB. The low noise amplifier gain can be set to 20 dB, 25 dB or 30 dB. The Quickset function will recommend the best setting for the B32 step attenuator and the B302 low noise amplifier combined based on the user-supplied specifications of the DUT.

Additionally, the LNA module includes bandpass for frequencies above 40 GHz. The R&S®ZNA switches to harmonic mixing mode in this frequency region which requires noise contributions at lower harmonics to be filtered out.

5.2.3 Reversed Coupler

- ▶ Goal: Increase sensitivity of the measurement receiver by decreasing its noise figure.
- ▶ DUTs: DUTs with low gain and low noise figure, measurements below 1 GHz.

For devices with very low output noise power, it may be necessary to further reduce the sensitivity of the b-wave measurement receiver.

The next option available is to reverse the receiving port coupler. This moves the measurement receiver to the lower loss "in-line" path of the receiving port coupler as shown in the simplified block diagram of Figure 5-6. The B16-configuration is shown in Figure 5-7. This configuration places the receiving port source into the coupled path of the directional coupler. Like activating the source monitor at port 1 (section 5.1.2), using the reversed coupler at port 2 can decrease measurement times by overcoming increased coupling loss for frequencies below 1 GHz.

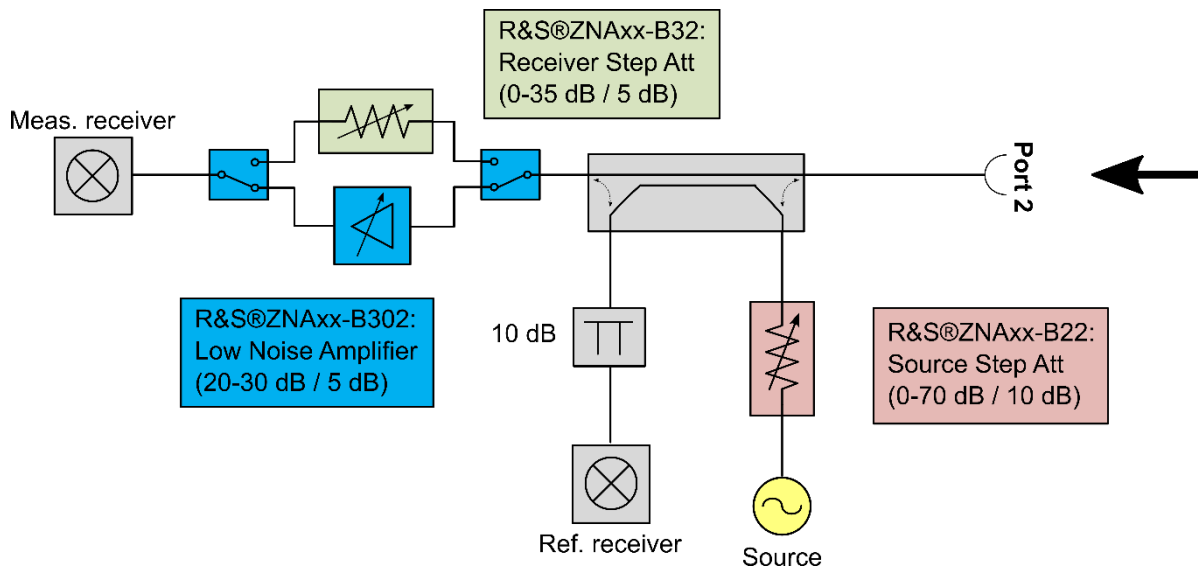

Figure 5-6: Simplified block diagram for the reversed coupler configuration at the receiving port

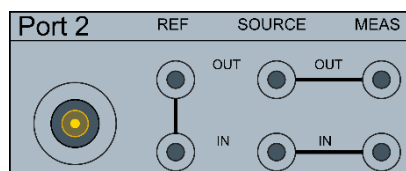

Figure 5-7: B16-configuration for the reversed coupler setup at port 2

The result is a 10 dB improvement in the receiving port sensitivity. And in exchange the output power of the port 2 source is reduced by 10 dB. This is a valuable trade off when measuring amplifiers with low output noise power. The Quickset function will recommend when to reverse the receiving port coupler.

5.2.4 External Low Noise Amplifiers

- ▶ Goal: Additional decrease of the receiver noise figure.
- ▶ DUTs: DUTs with low gain and low noise figure.

For additional flexibility, it may be necessary to utilize an external low noise amplifier during the measurement of the DUT.

An external low noise amplifier can be positioned in four different locations of the receiving port measurement path:

- ▶ The location offering the most sensitivity is the direct access path, where the output of the external low noise amplifier is connected to the input of the measurement receiver, using the B16 connector (Figure 5-8 a)). This reduces as much loss as possible in the measurement path.
- ▶ The next best option from a sensitivity point of view is to use the main connector of the receiving port (Figure 5-8 b)). In this configuration, the loss of the coupler is between the external pre-amplifier and the measurement receiver. If the receiving port coupler is reversed, this loss of the coupler will be in the single digits of dB. If the receiving port coupler is not reverse, this loss will be nominally 10 dB.
- ▶ The last two options for an external low noise amplifier are to place it in the B16 loop, between the b-wave output and the b-wave input connectors. For the standard coupler configuration, the connection is shown in Figure 5-8 c) and for the reversed coupler configuration the connection is shown in Figure 5-8 d). This places the coupler loss before the external amplifier. But in exchange, this placement allows the receiving port to be calibrated with respect to S-parameters, supporting a full two port calibration, in case that is required. The previous two options blocked the S-parameter calibration of the receiving port due to the location of the external low noise amplifier.

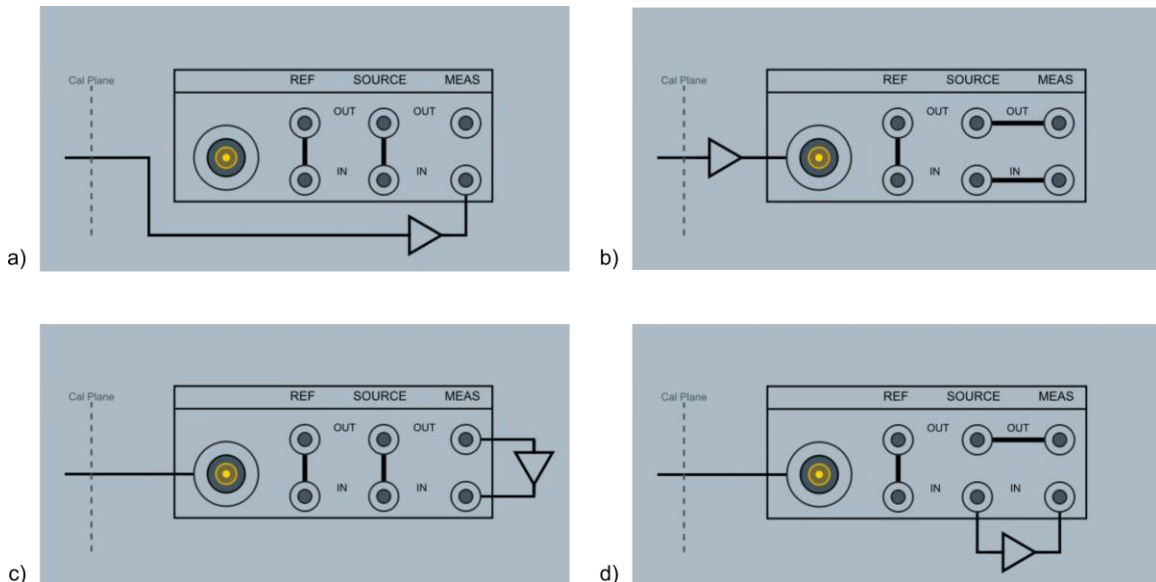

Figure 5-8: Options for positioning an external pre-amplifier: a) “Use external preamp (ext)”, b) “Use coupler (cpl)”, c) “Use reversed coupler (cpl rev)”, d) “Use direct access (DA)”

As mentioned in section 5.2.2, the internal LNA includes filters for filtering out undesired noise contributions above 40 GHz. If an external LNA is used external bandpass or highpass filters could be required above 40 GHz depending on the DUT gain and the gain and noise contribution of the external amplifier.

Alternatively, the external LNA can be used along with the internal LNA, which has built in bandpass and highpass filters which are automatically utilized during measurements above 40 GHz.

6 Conclusion

The R&S®ZNA Vector Network Analyzer (Figure 6-1) offers an easy to use noise figure application, K30, guiding the user toward an optimal measurement setup, calibration and measurement with a Quickset Wizard. The flexible setup and various hardware options allow an optimized configuration for different DUT characteristics. So, the noise figure measurement technique of the R&S®ZNA enables most devices to be measured without the need for any external accessories to be added.

The R&S®ZNA is an ideal instrument for making noise figure measurements due to its noise figure wizard, system error correction, and the ability to measure other RF parameters, such as intercept point, compression point and S-parameters in addition to noise figure.



Figure 6-1: The R&S®ZNA Vector Network Analyzer.

7 Literature

- [1] "IRE Standards on Methods of Measuring Noise in Linear Twoports, 1959," *Proceedings of the IRE*, vol. 48, no. 1, pp. 60-68, 1960.
- [2] Rohde & Schwarz, "dB or not dB?," 21 10 2019. [Online]. Available: https://www.rohde-schwarz.com/de/applikationen/db-oder-nicht-db-educational-note_230850-15534.html. [Accessed 06 12 2021].
- [3] H. Nyquist, "Thermal Agitation of Electric Charge in Conductors," *Phys. Rev.*, vol. 32, no. 1, pp. 110-113, Jul 1928.
- [4] H. Friis, "Noise Figures of Radio Receivers," *Proceedings of the IRE*, vol. 32, no. 7, pp. 419-422, 1944.

8 Ordering Information

Vector Network Analyzer

Designation	Type	Order No.
Vector network analyzer, 2 ports, 26.5 GHz, 3.5 mm connectors	R&S®ZNA26	1332.4500.22
Vector network analyzer, 4 ports, 26.5 GHz, 3.5 mm connectors	R&S®ZNA26	1332.4500.24
Vector network analyzer, 2 ports, 43.5 GHz, 2.92 mm connectors	R&S®ZNA43	1332.4500.42
Vector network analyzer, 4 ports, 43.5 GHz, 2.92 mm connectors	R&S®ZNA43	1332.4500.44
Vector network analyzer, 2 ports, 43.5 GHz, 2.4 mm connectors	R&S®ZNA43	1332.4500.43
Vector network analyzer, 4 ports, 43.5 GHz, 2.4 mm connectors	R&S®ZNA43	1332.4500.45
Vector network analyzer, 2 ports, 50 GHz, 2.4 mm connectors	R&S®ZNA50	1332.4500.52
Vector network analyzer, 4 ports, 50 GHz, 2.4 mm connectors	R&S®ZNA50	1332.4500.54
Vector network analyzer, 2 ports, 67 GHz, 1.85 mm connectors	R&S®ZNA67	1332.4500.62
Vector network analyzer, 4 ports, 67 GHz, 1.85 mm connectors	R&S®ZNA67	1332.4500.64

Hardware Options for the R&S®ZNA used for noise figure measurements

Designation	Type	Order No.
Direct source and receiver access, for R&S®ZNA26		
for 2-port model	R&S®ZNA26-B16	1332.4581.22
for 4-port model	R&S®ZNA26-B16	1332.4581.24
Direct source and receiver access, for R&S®ZNA43		
for 2-port model	R&S®ZNA43-B16	1332.4581.42
for 4-port model	R&S®ZNA43-B16	1332.4581.44
Direct source and receiver access, for R&S®ZNA50		
for 2-port model	R&S®ZNA50-B16	1332.6278.52
for 4-port model	R&S®ZNA50-B16	1332.6278.54
Direct source and receiver access, for R&S®ZNA67		
for 2-port model	R&S®ZNA67-B16	1332.6278.62
for 4-port model	R&S®ZNA67-B16	1332.6278.64
Source step attenuator, for R&S®ZNA26		
Port 1	R&S®ZNA26-B21	1332.4630.21
Port 2	R&S®ZNA26-B22	1332.4630.22
Port 3	R&S®ZNA26-B23	1332.4630.23
Port 4	R&S®ZNA26-B24	1332.4630.24
Source step attenuator, for R&S®ZNA43		
Port 1	R&S®ZNA43-B21	1332.4646.21
Port 2	R&S®ZNA43-B22	1332.4646.22
Port 3	R&S®ZNA43-B23	1332.4646.23
Port 4	R&S®ZNA43-B24	1332.4646.24
Source step attenuator, for R&S®ZNA50		
Port 1	R&S®ZNA50-B21	1332.5188.21
Port 2	R&S®ZNA50-B22	1332.5188.22
Port 3	R&S®ZNA50-B23	1332.5188.23
Port 4	R&S®ZNA50-B24	1332.5188.24

Designation	Type	Order No.
Source step attenuator, for R&S®ZNA67		
Port 1	R&S®ZNA67-B21	1332.5194.21
Port 2	R&S®ZNA67-B22	1332.5194.22
Port 3	R&S®ZNA67-B23	1332.5194.23
Port 4	R&S®ZNA67-B24	1332.5194.24
Receiver step attenuator, for R&S®ZNA26		
Port 1	R&S®ZNA26-B31	1332.4700.31
Port 2	R&S®ZNA26-B32	1332.4700.32
Port 3	R&S®ZNA26-B33	1332.4700.33
Port 4	R&S®ZNA26-B34	1332.4700.34
Receiver step attenuator, for R&S®ZNA43		
Port 1	R&S®ZNA43-B31	1332.4717.31
Port 2	R&S®ZNA43-B32	1332.4717.32
Port 3	R&S®ZNA43-B33	1332.4717.33
Port 4	R&S®ZNA43-B34	1332.4717.34
Receiver step attenuator, for R&S®ZNA50		
Port 1	R&S®ZNA50-B31	1332.5165.31
Port 2	R&S®ZNA50-B32	1332.5165.32
Port 3	R&S®ZNA50-B33	1332.5165.33
Port 4	R&S®ZNA50-B34	1332.5165.34
Receiver step attenuator, for R&S®ZNA67		
Port 1	R&S®ZNA67-B31	1332.5171.31
Port 2	R&S®ZNA67-B32	1332.5171.32
Port 3	R&S®ZNA67-B33	1332.5171.33
Port 4	R&S®ZNA67-B34	1332.5171.34
Source monitor access port 1, for R&S®ZNA26 (2-port model)	R&S®ZNA26-B161	1332.4823.51
Source monitor access port 1 and port 3, for R&S®ZNA26 (4-port model)	R&S®ZNA26-B163	1332.4823.53
Source monitor access port 1, for R&S®ZNA43 (2-port model)	R&S®ZNA43-B161	1332.4830.51
Source monitor access port 1 and port 3, for R&S®ZNA43 (4-port model)	R&S®ZNA43-B163	1332.4830.53
Low-noise amplifier port 2, for R&S®ZNA26	R&S®ZNA26-B302	1332.4752.12
Low-noise amplifier port 2, for R&S®ZNA43	R&S®ZNA43-B302	1332.4769.12
Low-power spurious reduction port 1, for R&S®ZNA26	R&S®ZNA26-B501	1332.5220.11
Low-power spurious reduction port 1, for R&S®ZNA43	R&S®ZNA43-B501	1332.5236.11

Software Option for the R&S®ZNA used for noise figure measurements

Designation	Type	Order No.
Noise figure measurement	R&S®ZNA-K30	1332.5465.02

Calibration Unit*

Designation	Type	Order No.
Calibration unit, 2 ports, 3.5 mm, female, 9 kHz to 26.5 GHz	R&S®ZN-Z50	1335.6904.32
Calibration unit, 2 ports, 2.92 mm, female, 9 kHz to 40 GHz, characterized up to 43.5 GHz	R&S®ZN-Z54	1335.7117.92
Calibration unit, 2 ports, 2.4 mm, female, 9 kHz to 50 GHz	R&S®ZN-Z55	1335.7181.42
Calibration unit, 2 ports, 1.85 mm, female, 5 GHz to 67 GHz	R&S®ZN-Z156	1332.7239.02

Power Sensor*

Designation	Type	Order No.
Three-path diode power sensor 100 pW to 200 mW, 10 MHz to 33 GHz	R&S®NRP33S	1419.0064.02
Three-path diode power sensor 100 pW to 100 mW, 50 MHz to 40 GHz	R&S®NRP40S	1419.0041.02
Three-path diode power sensor 100 pW to 100 mW, 50 MHz to 50 GHz	R&S®NRP50S	1419.0087.02
Three-path diode power sensor 100 pW to 100 mW, 50 MHz to 67 GHz	R&S®NRP67S	1424.6396.02

* Other Power Sensors and Calibration Units are suitable as well. Please ask your local representative for a suitable configuration according to all your needs.

Example setup for noise figure measurements up to 40 GHz with a four port R&S®ZNA where port 1 is the driving port and port 2 is the receiving port:

Designation	Type	Order No.
Vector Network Analyzer		
Vector network analyzer, 4 ports, 43.5 GHz, 2.92 mm connectors	R&S®ZNA43	1332.4500.44
Hardware Options		
Direct source and receiver access, for R&S®ZNA43 (4-port model)	R&S®ZNA43-B16	1332.4581.44
Source step attenuator, for R&S®ZNA43, port 1	R&S®ZNA43-B21	1332.4646.21
Receiver step attenuator, for R&S®ZNA43, port 2	R&S®ZNA43-B32	1332.4717.32
Source monitor access port 1 and port 3, for R&S®ZNA43 (4-port model)	R&S®ZNA43-B163	1332.4830.53
Low-noise amplifier port 2, for R&S®ZNA43	R&S®ZNA43-B302	1332.4769.12
Low-power spurious reduction port 1, for R&S®ZNA43	R&S®ZNA43-B501	1332.5236.11
Software Option		
Noise figure measurement	R&S®ZNA-K30	1332.5465.02
Calibration Unit		
Calibration unit, 2 ports, 2.92 mm, female, 9 kHz to 40 GHz, characterized up to 43.5 GHz	R&S®ZN-Z54	1335.7117.92
Power Sensor		
Three-path diode power sensor 100 pW to 100 mW, 50 MHz to 40 GHz	R&S®NRP40S	1419.0041.02

Rohde & Schwarz

The Rohde & Schwarz electronics group offers innovative solutions in the following business fields: test and measurement, broadcast and media, secure communications, cybersecurity, monitoring and network testing. Founded more than 80 years ago, the independent company which is headquartered in Munich, Germany, has an extensive sales and service network with locations in more than 70 countries.

www.rohde-schwarz.com



Rohde & Schwarz training

www.training.rohde-schwarz.com

Rohde & Schwarz customer support

www.rohde-schwarz.com/support



R&S® is a registered trademark of Rohde & Schwarz GmbH & Co. KG
Trade names are trademarks of the owners.

1SL378 | Version 0e | 12.2021

Application Note | The Cold Source Technique for Noise Figure Measurements

Data without tolerance limits is not binding | Subject to change

© 2021 Rohde & Schwarz GmbH & Co. KG | 81671 Munich, Germany

www.rohde-schwarz.com